

Honeywell VE4100B3000

Honeywell

www.honeywell.ru.com

VE Series

Class "A" Gas Valves

Product handbook



APPLICATION

These series class A gas valves are used for control and regulation of gaseous fluids in gas power burners, atmospheric gas boilers, melting furnaces, incinerators and other gas consuming appliances.

CONTENTS

General

Description	2
Features	2
Model chart	3

Technical

Specifications	4--6
Performance characteristics	7
Capacity curves	8--9
Dimensional drawing 1000 series	10
Dimensional drawing 3000 series	11

Installation and operation

Installation and final checkout	12
Adjustments an final checkout	13
Construction and working principles	14

Various

Standards and approvals	15
Ordering information	16
Replacement parts and accessories	17

DESCRIPTION

The VE series gas valves offer a series of functionalities:

- Gas valves, Normally Closed, consisting of a direct ON/OFF operator for opening/closing of the valve.
- Gas valves for use with Honeywell V4055, V4062 and V9055 fluid power actuators.
- Relief valves with or without position indication switch, Normally Open, consisting of direct electric ON/OFF operator for opening/closing of the valve.

The VE series gas valves are suitable for the control of gaseous fluids in gas consuming appliances according to international standards.

The VE series gas valves meet the class A specification according EN 161.

The VE series gas valves cover a wide range of pipe sizes from $\frac{3}{8}$ " (DN 10) up to and including 3" (DN 80).

The VE series gas valves have threaded connections from $\frac{3}{8}$ " (DN 10) up to and including 2 $\frac{1}{2}$ " (DN 65).

The VE series gas valves with pipe sizes 2 $\frac{1}{2}$ " (DN 65) and 4" (DN 100) have flange connection.

The VE series gas valves $\frac{3}{8}$ " (DN 10) and $\frac{1}{2}$ " (DN 15) have an maximum supply pressure of 350 mbar.

The VE series gas valves $\frac{3}{4}$ " (DN 20) up to and including 4" (DN 100) have an maximum supply pressure of 200 mbar or 360mbar on request.

The VE series gas valves have test points for inlet and outlet gas pressure. The VE series gas valves have an inlet screen for protecting the valve against ingress of dirt.

FEATURES

- Class A valve for control of gas consuming appliances.
- The VE....X series gas valves except VE....S series have a spring loaded valve disc, closed when de-energized.
- The VE....S series gas valves have a spring loaded valve disc, opened when de-energized.
- Incorporating time proven design concepts assuring reliability.
- All VE.... series gas valves have an internal fine mesh screen.
- Two R $\frac{1}{4}$ " connections for inlet pressure at each side of the electro magnetic gas valve.
- The VE...X 1... series gas valves have a wrench boss as well on inlet side as on outlet side for pipe fitting incorporated in the valve housing.
- The VE.... series gas valves may be assembled on the pipe linewith in plus or minus 90 degrees of the vertical axel.
- The VE....X 3... series gas valves (flange connection) have two ($\frac{1}{4}$ " inlet pressure taps and two $\frac{1}{4}$ " outlet pressure taps at either side.
- The VE....X 3... and VE5...X 3... series gas valves have at inlet side two 1" ISO 7--1 connection taps.
- The VE....X 3... and VE5...X 3... series gas valves are equipped at both sides with mounting holes to adapt a pilot solenoid valve combination, to allow either internal or external pilot gas. Futhermore these valves are equipped with two M6 mounting holes to adapt an A4020A electronic leak test controller (see dimensional drawing page 11).
- The VEB series gas valves have an adjustable flow rate regulator on top of the coil.
- The VE series gas valves have a field replaceable coil.
- The VE series gas valves have a field replaceable rectifier board.
- The VEC series gas valves have adjustment for:
 - step pressure
 - flow rate and
 - opening speed on top of the coil.
- The VE....S series gas valves normally open relief valves are equipped with or without a position indication switch.
- The VE5...X 3... series gas valves can be equipped with a wide range of Honeywell fluid power actuators. These fluid power actuators are field replaceable.
- The VE series solenoid gas valves have electrical connection by terminal block with incorporated rectifier board.
- The VE series solenoid gas valves have coils turnable over 360°.
- Cable strain relief can be achieved by PG 11 cable gland.
- The VE series gas valves cover a wide range of pipe sizes from DN 10 up to and including DN 80.

Electrical connection

- Supply voltages 24, 110, 220 and 240V 50/60 Hz.
- Electrical enclosure according to IP 54 unless other specification.
- Electrical enclosure VE....S 1... series gas valves with switch according to IP 50

MODEL CHART

Options	1000 series (internal threaded)	3000 series (flange connection)
Range: DN 10 3/8"	VE..10	--
DN 15 1/2"	VE..15	--
DN 20 3/4"	VE..20	--
DN 25 1"	VE..25	--
DN 32 1 1/4"	VE..32	--
DN 40 1 1/2"	VE..40	--
DN 50 2"	VE..050	--
DN 65 2 1/2"	VE..65	VE..65
DN 80 3"	VE..80	VE..80
DN 100 4"	VE..100	VE..100
Non regulated ON/OFF (VE....A XXXX)	Standard	Optional
Flow regulator (VE....B XXXX)	Optional	Standard
Adjustable opening and flow regulator (VE....C XXXX)	Optional ¹⁾	Not available
Motorised opening: ON/OFF (VE5...A XXXX)	Not available	VE5065A 3xxx VE5085A 3xxx
Motorised opening: characterized (VE5...C XXXX)	Not available	VE5065C 3xxx VE5085C 3xxx
Safety relief valve, ON/OFF, Normally Open, with or without position indication switch (VE....S XXXX)	Optional for: VE..20 VE..25	Not available

¹⁾Except VE..65/VE..80

SPECIFICATIONS

Models

The VE series consists of solenoid gas valves series and gas valves suitable for combining with Honeywell V4055, V4062 and V9055 fluid power actuators.

VE series solenoid gas valves

- VE..10 (DN 10)
- VE..15 (DN 15)
- VE..20 (DN 20)
- VE..25 (DN 25)
- VE..32 (DN 32)
- VE..40 (DN 40)
- VE..50 (DN 50)
- VE..65 (DN 65)
- VE..80 (DN 80)
- VE..100 (DN 100)

VE series suitable for fluid power actuators

- VE5065 (DN 65)
- VE5080 (DN 80)

Pipe sizes 1000 series

Inlet and outlet 3/8" up to 2 1/2" internal parallel pipe thread according to ISO 7--1

Pipe sizes 3000 series

Flanged connection DN 65 and DN 80 according to DN 16 UNI 2223.

Torsion and bending stress

Pipe connections meet Group 2 according EN 161 requirements.

Ambient temperature

--15 °C ... 60 °C

Supply voltage

- 24 V, 50/60 Hz
- 110 V, 50/60 Hz
- 220 V, 50/60 Hz
- 240 V, 50/60 Hz

The applicable voltage is led to the solenoid coil via a rectified circuit.

Dimensions

- 1000 series: See page 10
- 3000 series: See page 11

Electrical connection

Wiring on terminal block on box Cable entry Pg 11.

Coil insulation solenoid valves

Insulation material according class F

Enclosure

- IP 54 unless otherwise specified
- IP 50 for VE4...S 1... series with position indication switch
- IP 65 on request

Capacity

See page 8 and 9

Maximum operating pressure

Model	Maximum operating pressure (mbar)
VE..10	360
VE..15	360
VE..20	200 or 360
VE..25	200 or 360
VE..32	200 or 360
VE..40	200 or 360
VE..50	200 or 360
VE..65	200 or 360
VE..80	200 or 360
VE5065	200 or 360
VE5080	200 or 360
VE..100	200 or 360

Power Consumption Version A - 200 mbar

Model number	12 Volt, 50/60Hz nominal	12 Volt, 50/60Hz 110% of nominal	24Volt, 50/60Hz nominal	24 Volt, 50/60Hz 110% of nominal	24 Volt (dc), nominal	24 Volt (dc), 110% of nominal	110 Volt, 50/60Hz nominal	110 Volt, 50/60Hz 110% of nominal	220 Volt, 50/60Hz nominal	220 Volt, 50/60Hz 110% of nominal
VE..10A	20	24	18	22	17	21	14	17	14	17
VE..15A	20	24	18	22	17	21	14	17	14	17
VE..20A	30	36	21	25	24	29	21	25	20	24
VE..25A	30	36	21	25	24	29	21	25	20	24
VE..32A			53	64	67	81	47	57	40	48
VE..40A			53	64	67	81	47	57	40	48
VE..50A			49	59	64	77	48	58	41	50
VE..65A							72	87	83	100
VE..80A							71	86	85	103
VE..100A start									162	196
VE..100A work							163	197	41	50

Power Consumption Version A - 360 mbar

Model number	12 Volt, 50/60Hz nominal	12 Volt, 50/60Hz 110% of nominal	24Volt, 50/60Hz nominal	24 Volt, 50/60Hz 110% of nominal	24 Volt (dc), nominal	24 Volt (dc), 110% of nominal	110 Volt, 50/60Hz nominal	110 Volt, 50/60Hz 110% of nominal	220 Volt, 50/60Hz nominal	220 Volt, 50/60Hz 110% of nominal
VE..10A			18	22	17	21	14	17	14	17
VE..15A			18	22	17	21	14	17	14	17
VE..20A							21	25	20	24
VE..25A							21	25	20	24
VE..32A							48	58	41	50
VE..40A							48	58	41	50
VE..50A							63	76	60	73
VE..65A								0		0
VE..80A start							248	300	287	347
VE..80A work							62	75	70	85
VE..100A start							218	264	612	741
VE..100A work							55	67	153	185

Power Consumption Version B, C - 200 mbar

Model number	12 Volt, 50/60Hz nominal	12 Volt, 50/60Hz 110% of nominal	24Volt, 50/60Hz nominal	24 Volt, 50/60Hz 110% of nominal	24 Volt (dc), nominal	24 Volt (dc), 110% of nominal	110 Volt, 50/60Hz nominal	110 Volt, 50/60Hz 110% of nominal	220 Volt, 50/60Hz nominal	220 Volt, 50/60Hz 110% of nominal
VE..10B,C			18	22	17	21	14	17	14	17
VE..15B,C			18	22	17	21	14	17	14	17
VE..20B,C			21	25	24	29	21	25	20	24
VE..25B,C			21	25	24	29	21	25	20	24
VE..32B,C			53	64	67	81	47	57	40	48
VE..40B,C			53	64	67	81	47	57	40	48
VE..50B,C			49	59	64	77	48	58	41	50
VE..65B							71	86	62	75
VE..80B							71	86	85	103
VE..100B start									162	196
VE..100B work							163	197	41	50

Power Consumption Version B, C - 360 mbar

Model number	12 Volt, 50/60Hz nominal	12 Volt, 50/60Hz 110% of nominal	24Volt, 50/60Hz nominal	24 Volt, 50/60Hz 110% of nominal	24 Volt (dc), nominal	24 Volt (dc), 110% of nominal	110 Volt, 50/60Hz nominal	110 Volt, 50/60Hz 110% of nominal	220 Volt, 50/60Hz nominal	220 Volt, 50/60Hz 110% of nominal
VE..10B,C			18	22	17	21	14	17	14	17
VE..15B,C			18	22	17	21	14	17	14	17
VE..20B,d							21	25	20	24
VE..25B,C							21	25	20	24
VE..32B,C							48	58	41	50
VE..40B,C							48	58	41	50
VE..50B,C							63	76	60	73
VE..65B							162	196	83	100
VE..80B start							248	300	287	347
VE..80B work							62	75	70	85
VE..100B start							218	264	612	741
VE..100B work							55	67	153	185

Power Consumption Version S - 200 mbar

Model number	12 Volt, 50/60Hz nominal	12 Volt, 50/60Hz 110% of nominal	24Volt, 50/60Hz nominal	24 Volt, 50/60Hz 110% of nominal	24 Volt (dc), nominal	24 Volt (dc), 110% of nominal	110 Volt, 50/60Hz nominal	110 Volt, 50/60Hz 110% of nominal	220 Volt, 50/60Hz nominal	220 Volt, 50/60Hz 110% of nominal
VE..20S			16	19	17	21	14	17	16	19

Power Consumption Version S - 360 mbar

Model number	12 Volt, 50/60Hz nominal	12 Volt, 50/60Hz 110% of nominal	24Volt, 50/60Hz nominal	24 Volt, 50/60Hz 110% of nominal	24 Volt (dc), nominal	24 Volt (dc), 110% of nominal	110 Volt, 50/60Hz nominal	110 Volt, 50/60Hz 110% of nominal	220 Volt, 50/60Hz nominal	220 Volt, 50/60Hz 110% of nominal
VE..20S			16	19	17	21	14	17	16	19

PERFORMANCE CHARACTERISTICS

Maximum allowable leakage

Valve size	Test pressure 1 (mbar)	Test pressure 2 (mbar)	Maximum allowable leakage rate	
			Internal leakage (cm ³ /h)	External leakage (cm ³ /h)
DN 10	6	525	40	40
DN 15	6	525	40	40
DN 20	6	300	40	40
DN 25	6	300	60	60
DN 32	6	300	60	60
DN 40	6	300	60	60
DN 50	6	300	60	60
DN 65	6	300	60	60
DN 80	6	300	60	60
DN 100	6	300	60	60

Opening time (except VE5... series)

A,B,S version: less than 1 second

C version: adjustable from 1 up to 30 seconds at rated capacity

The opening characteristic is factory set at approx 6 seconds at the following conditions:

- measured at 80 % of rated capacity
- 30 mbar supply pressure
- nominal voltage
- 20 °C
- 2.5 mbar pressure drop
- no step pressure

Due to the influence of ambient temperature (-15 ... 60 °C) the adjusted opening time of 6 seconds measured at 80% of adjusted flow rate can vary +/- 4 seconds.

D,E version: 5 or 30 seconds
(depending of actuator)

Closing time VE...A, B, C and

S series (except VE5... series)

Less than 1 second

Maximum working frequency

A,B,S version: 20 cycles per minute

C version: 1 cycle per minute

VE5... series: 1 cycle per 2 minutes

Duty cycle

Coil suitable for permanent energization

Operational voltage range

The gas valve will function satisfactory between 85% and 110% of the rated voltage.

Rated voltage:

- 24 V, 50/60 Hz
- 115 V, 50/60 Hz
- 230 V, 50/60 Hz

Design life

Model	Number of cycles
VE..10	200.000
VE..15	200.000
VE..20	200.000
VE..25	200.000
VE..32	100.000
VE..40	100.000
VE..50	100.000
VE..65	100.000
VE..80	100.000
VE..100	100.000
VE5065	100.000
VE5080	100.000

CAPACITY CURVE DN 10, DN 15, DN 20, DN 25, DN 32 AND DN 40 (THREADED CONNECTION)

Capacity in m³/h air at $\Delta p = 2.5$ mbar

3/8" DN 10	1/2" DN 15	3/4" DN 20	1" DN 25	1 1/4" DN 32	1 1/2" DN 40
5	6.4	14.8	16.7	38.5	47.1

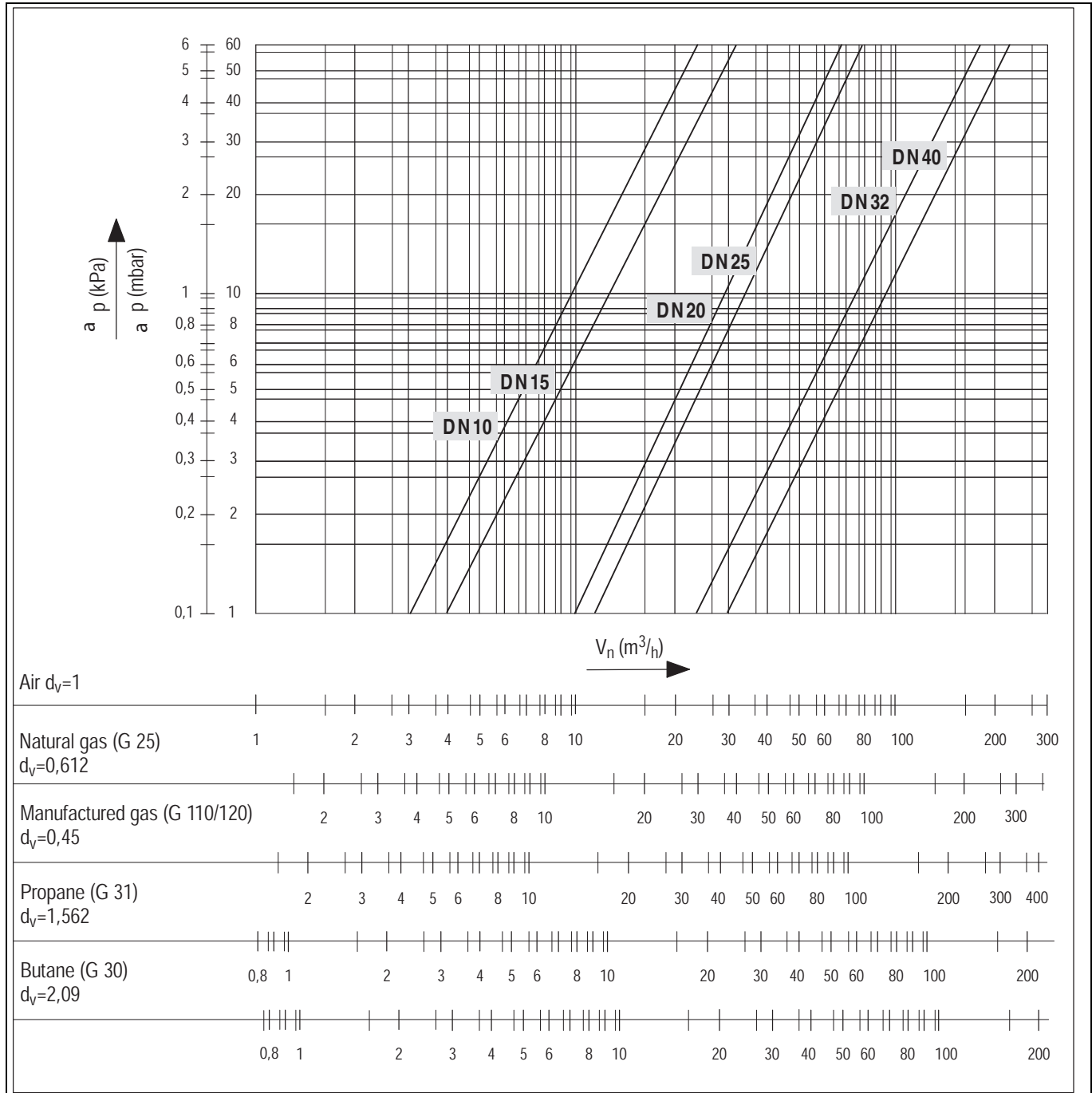

CAPACITY CURVE DN 50, DN 65 AND DN 80 (TREADED AND FLANGED CONNECTION)

Capacity in m³/h air at Δp = 2.5 mbar

2" DN 50	2 1/2" DN 15	3" DN 20	4" DN 100
66.7	94.2	131	225

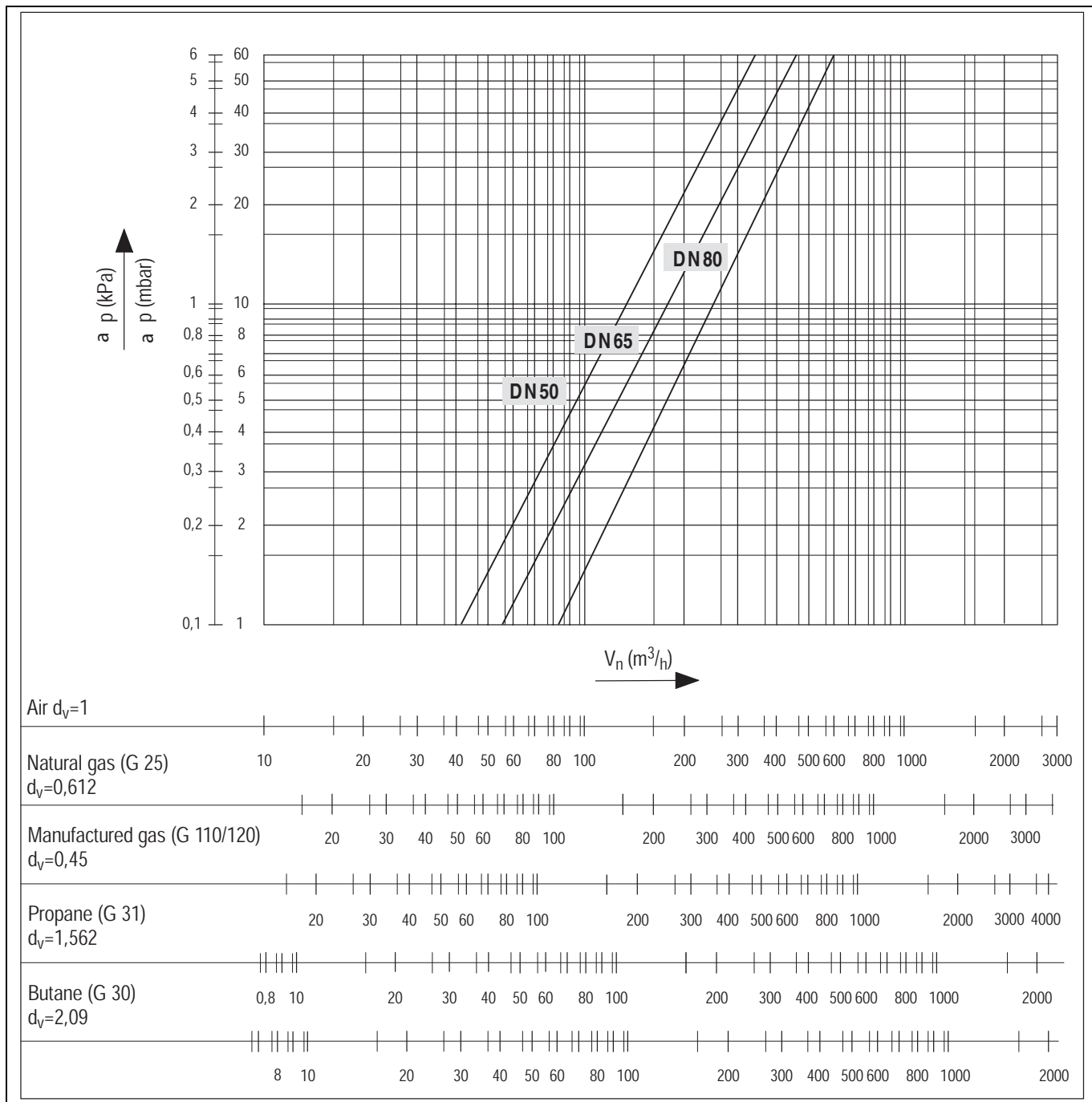

DIMENSIONAL DRAWING 1000 SERIES

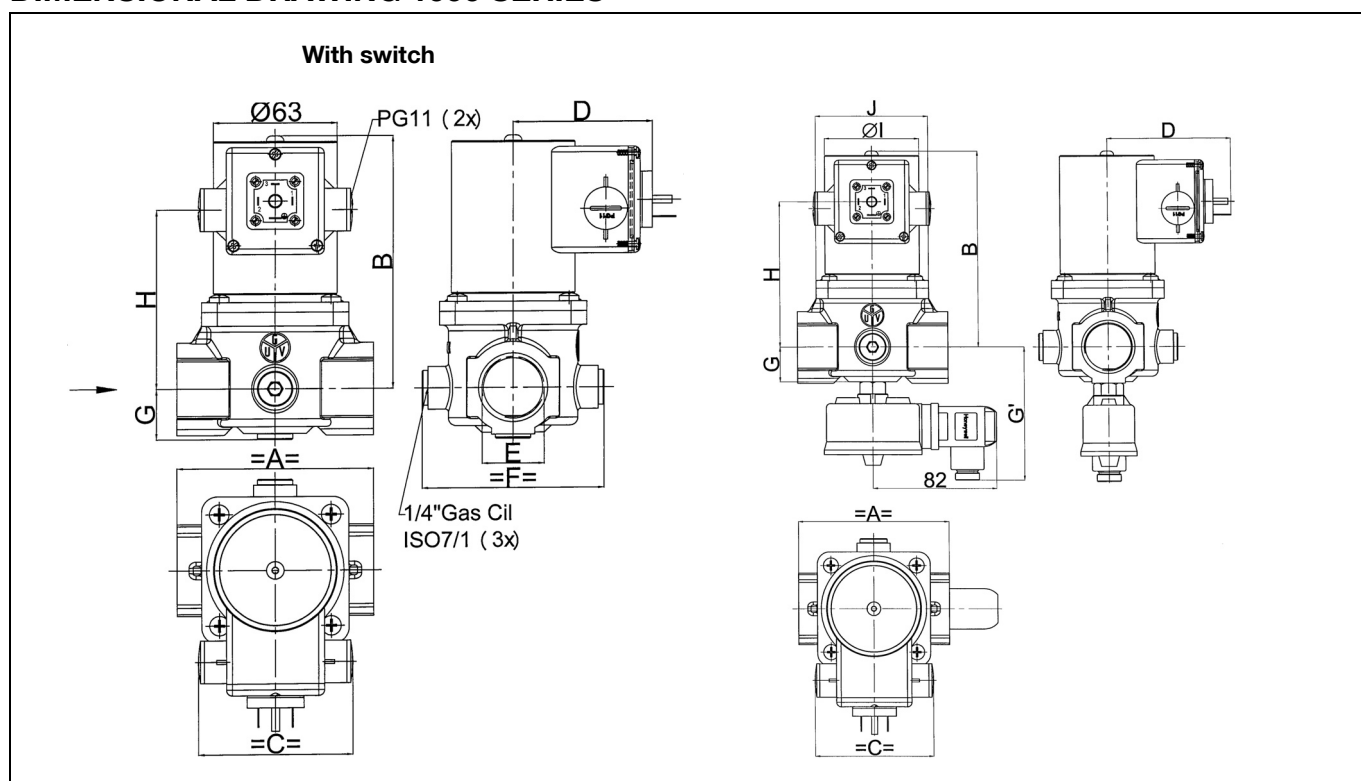

Model	Connection	Dimensions (mm)							Weight (kg)
		A	B	C	D	E	F	G	
VE..10A	DN 10	64.5	100	55	67	70.5	62.5	15	1.1
VE..10B			119						1.1
VE..10C			153						1.2
VE..15A	DN 15	64.5	100	55	67	70.5	62.5	15	1.1
VE..15A			119						1.1
VE..15C			153						1.2
VE..20A	DN 20	86.5	132	63	71	81	93	24	1.9
VE..20B			151						1.9
VE..20C			185						2.3
VE..25A	DN 25	100	132	63	71	92.5	93	24	2.0
VE..25B			151						2.0
VE..25C			185						2.4
VE..32A	DN 32	150	180	95	86	113.5	150	33	5.8
VE..32B			199						5.8
VE..32C			233						6.1
VE..40A	DN 40	150	180	95	86	113.5	150	33	5.8
VE..40B			199						5.8
VE..40C			233						6.1
VE..50A	DN 50	170	199	95	86	138.5	159	41	6.4
VE..50B			218						6.4
VE..50C			252						6.7
VE..65A	DN 65	170	246	130	104	171	203	55	13.0
VE..65B			-						-
VE..65C			-						-

DIMENSIONAL DRAWING 3000 SERIES

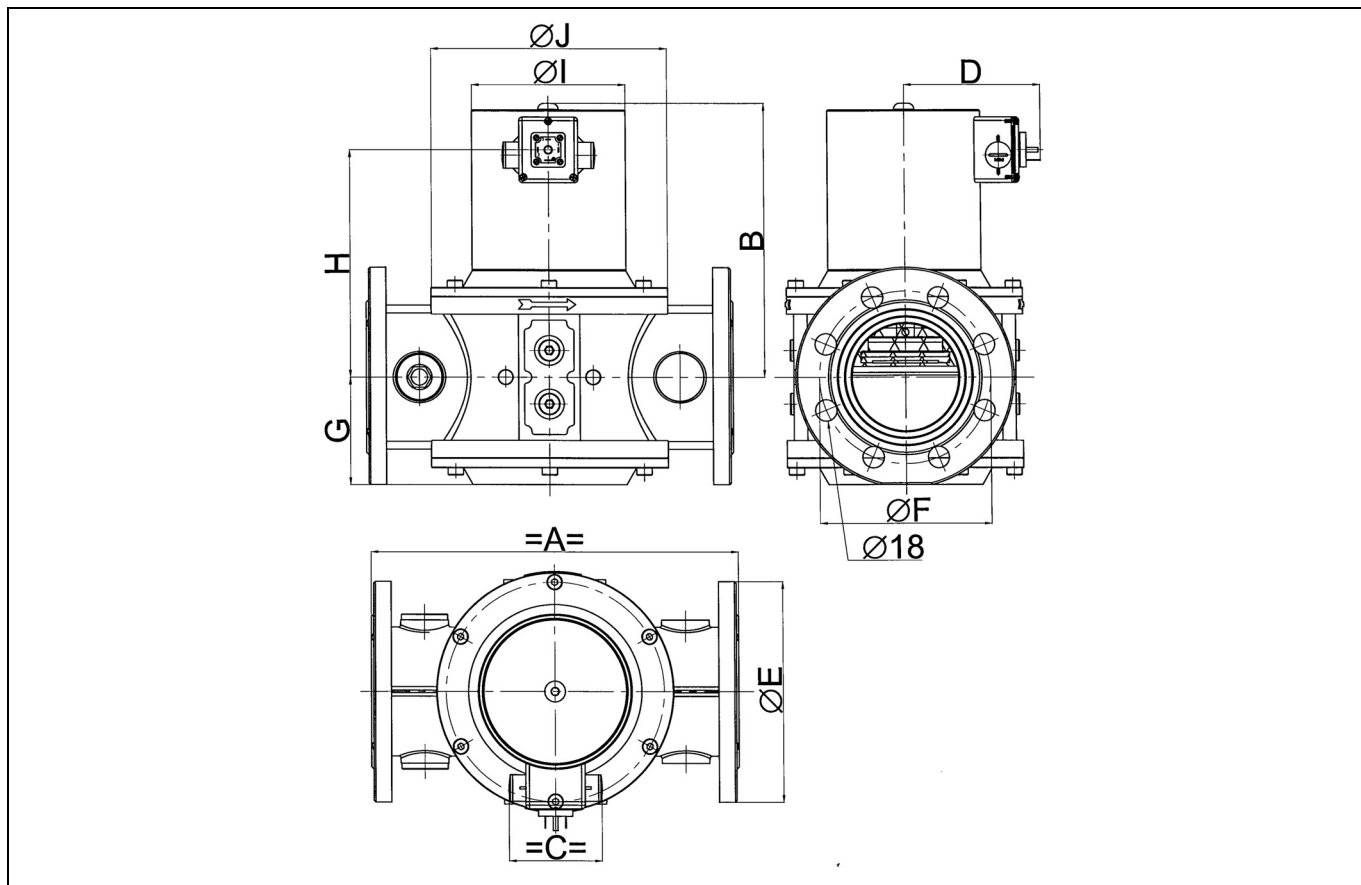

Model	Conne- ction	Dimensions (mm)											Weight (kg)
		A	B	C	D	E	F	G	H	J	K	L(-)	
VE..65A3xxx	DN 65	310	230	Ø130	98	200	187	90	79	185	1456	4	15
VE..65B3xxx			250										
VE..80A3xxx	DN 80	310	230	Ø130	120	200	180	91	92	200	160	8	15
VE..80B3xxx			250										
VE..100A3xxx	DN 100	350	280	Ø159	135	252	226	103	92	206	180	8	20
VE..100B3xxx			300										
VE..5065A3xxx	DN 65	310	338	172x127	-	200	-	90	-	185	145	4	10
VE5065C3xxx													
VE5080A3xxx	DN 80	310	338	172x127	-	200	-	91	-	200	160	8	10
VE5080C3xxx													
VE50100A3xxx	DN 100	350	345	172x127	-	252	-	103	-	206	180	8	15
VE50100C3xxx													

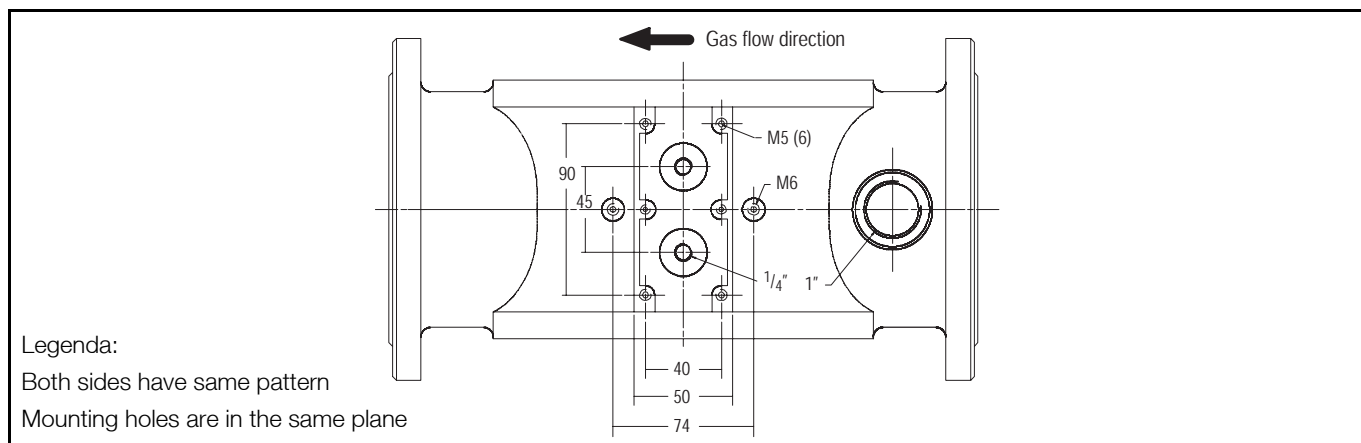

INSTALLATION

Warning

- Take care that installer is a trained experienced service man.
- Turn off gas supply before starting installation.
- Disconnect power supply to prevent electrical shock and/or equipment damage.

Mounting position

The gas valve can be mounted plus or minus 90 degrees from the vertical.

Mounting location

The distance between the gas valve and the wall/ground, must be at least 30 cm.

Warning

- The outlet of a pressure relief valve (VE4000S series) must always be connected to open atmosphere.

Main gas connection threaded valves

- Take care that dirt cannot enter the gas valve during handling.
- Ensure the gas flows in the same direction as the arrow on the housing of the gas valve.
- Use a sound taper fitting with thread according to ISO 7--1 (BS 21, DIN2999) or a piece of new, properly reamed pipe, free from swarf.
- Do not thread or tighten the pipe or pipe fitting too far. Otherwise valve distortion and malfunction could result.
- Apply a moderate amount of good quality thread compound to the pipe or fitting only, leaving the two end threads bare. PTFE tape may be used as an alternative.
- In order to tighten the pipe in the valve, do not use the actuator as a lever but use a suitable wrench operating on the wrench bosses.

Main gas connection flanged valves

- Take care that dirt cannot enter the gas valve during handling.
- Ensure the gas flows in the same direction as the arrow on the housing of the gas valve.
- Ensure that inlet and outlet flanges are in line and separated from each other enough to allow the valve to be mounted between them without damaging the gasket.
- Place gasket. If necessary grease it slightly to keep it in place.
- Mount gas valve between flanges using the bolts for each flange.

Warning

Tightness test after installation

- Paint all pipe connections and gaskets with a strong soap and water solution.
- Start the appliance and check for bubbles. If a leak is found in a pipe connection, remake the joint. A gasket leak can usually be stopped by tightening the mounting screws. Otherwise, replace the gas valve.

Electrical connection

Caution

- Switch off power supply before making electrical connections.
- Take care that wiring is in accordance with local regulations.

Use lead wire which can withstand 105 °C ambient.

The electric on/off operator is provided with a terminal block for electrical connections.

Wiring

Follow the instructions supplied by the appliance manufacturer.

ADJUSTMENTS AND FINAL CHECKOUT

Warning

Adjustments must be made by qualified persons only.

Caution

To ensure a safe closing of the valves, it is essential that voltage over the terminals of operators is reduced to 0 Volt.

VE... C SERIES

(see fig. 2 and 3)

The following characteristics can be adjusted:

- flow rate
- step pressure
- opening speed

Important

To ensure a satisfactory setting of the valve the pressure drop over the valve should be at least 10% of the supply pressure or 2.5 mbar which ever is the greatest.

VE... B SERIES

(see fig 1.)

Flow rate adjustment

- Remove the cap screw from top of the coil.
- Place a socket head wrench into the adjustment nut.
- Turn wrench counter--clockwise to increase or clockwise to decrease flow rate.
- Replace cap screw.

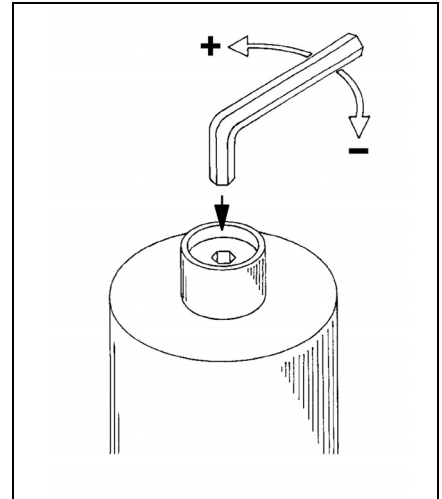

Flow rate adjustment

- Remove the cap from top of the coil by loosening both screws.
- Place a wrench on the adjustment hexagon nut.
- Turn wrench counter--clockwise to increase or clockwise to decrease the flow rate.
- Replace cap on top of the coil.

Step pressure adjustment

- Remove the cap from top of the coil by loosening both screws.
- Place a screw driver in the slot of adjustment screw which is situated in center of the valve.
- Turn screw driver counter--clockwise to increase or clockwise to decrease step pressure.
- Replace cap on top of the coil.

Opening speed adjustment

- Remove the cap from top of the coil by loosening both screws.
- Place screw driver in the slot of adjustment screw which is of center line.
- Turn screw driver counter--clockwise to increase the opening speed and therefore the time till full opening will decrease.
- Turn screw driver clockwise to decrease the opening speed and therefore the time till full opening will increase.
- Replace cap on top of the coil.

Final checkout of the installation

Set appliance in operation after any adjustment and observe several complete cycles to ensure that all burner components function correctly.

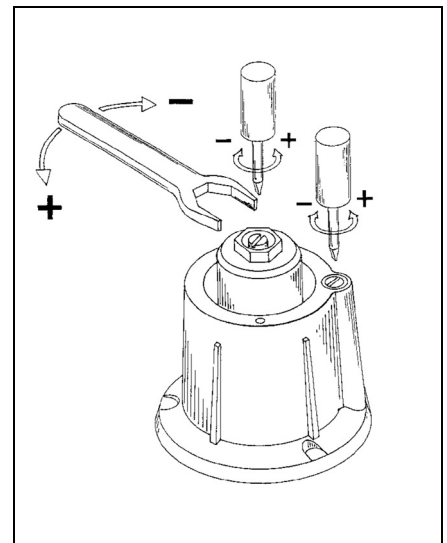
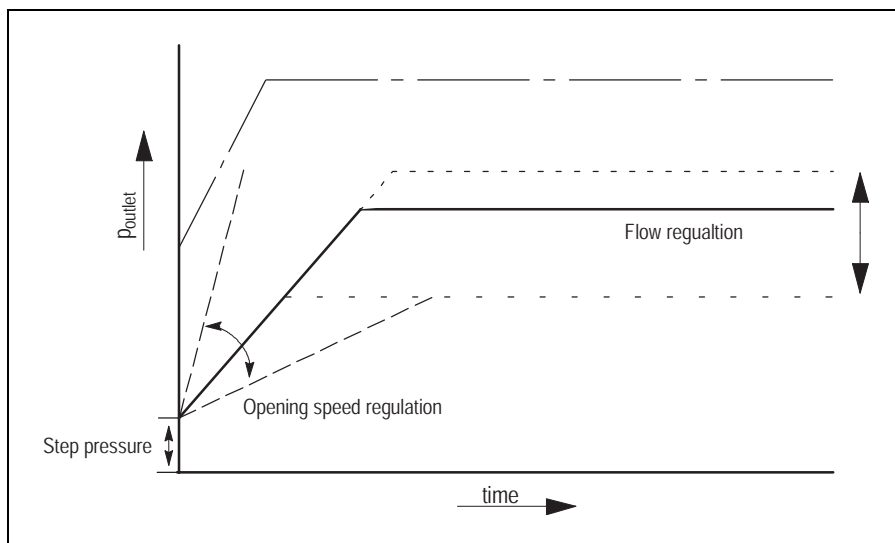

CONSTRUCTION AND WORKING PRINCIPLES

The VE Normally Closed series gas valves are Class A fail safe shut-off valves.

The valve is opened by energizing the direct ON/OFF operator.

The direct ON/OFF operator consists of a coil and stop sleeve assy. Inside the top sleeve assy is a plunger which is able to move up and down and thus opening or closing the valve.

The plunger is gliding on two antifriction bearings.

Flow regulation is done by adjustable plunger stroke.

A strainer made out of steel AISI 303 is incorporated in the gas valve.

Valve closing spring is made out of steel AISI 302.

Seals and gaskets are manufactured out of hydrocarbon resistant NBR according to DIN 3535 and EN 291.

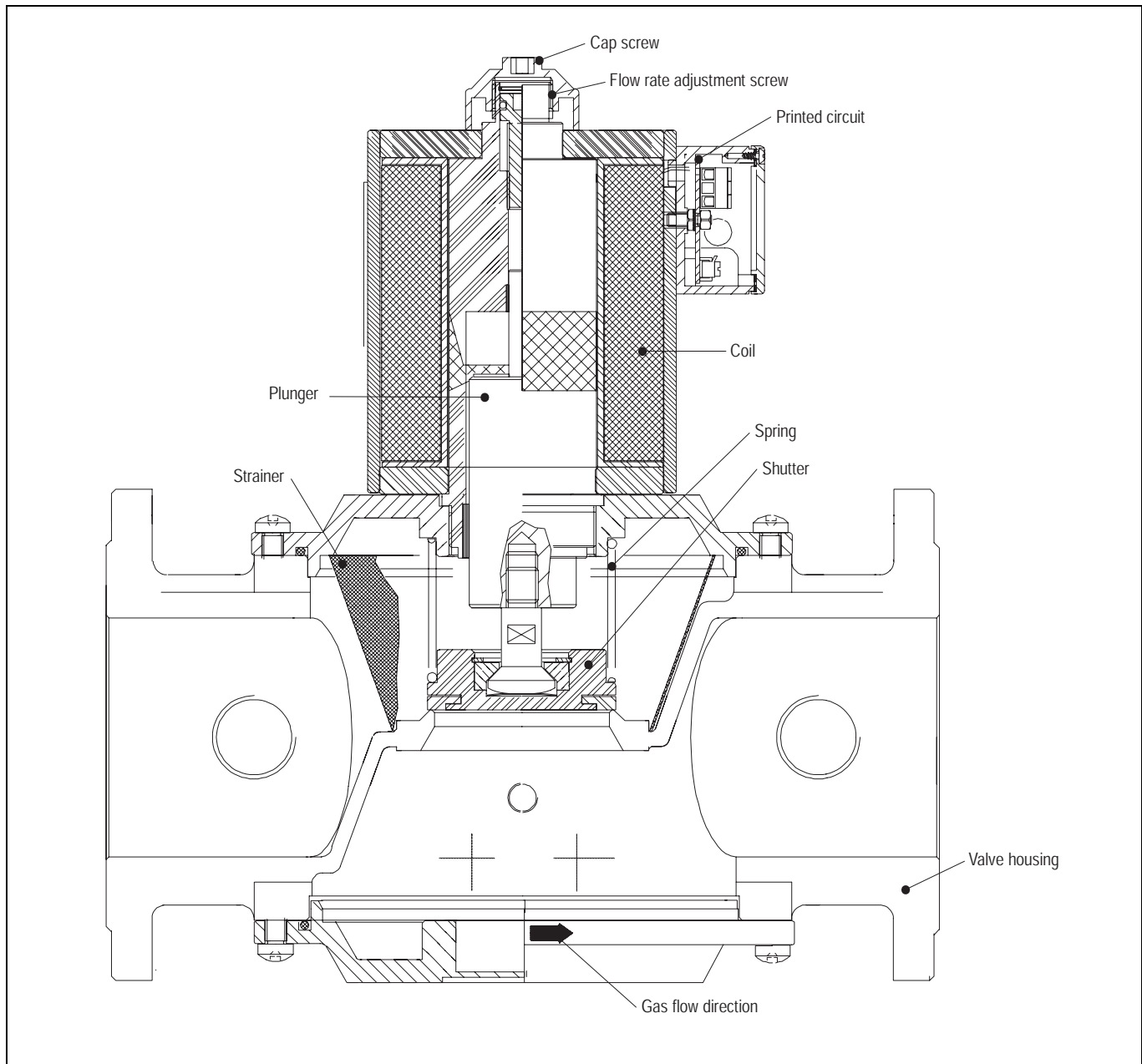

STANDARDS AND APPROVALS

Standards

The VE series gas valves have been designed to meet the European Standard EN 161.

The safety shut off valve meets class A requirements.

According to bending stress the gas valve meets the highest requirements.

Regarding electric safety, the VE series gas valves can be used in appliances according to European Standard for a household electrical requirements EN 60335 series and industrial applications.

The VE series gas valves also meet all Electro Magnetic Compatibility standards for non-industrial and industrial appliances.

Approvals

The VE series gas valves confirm with the following EC-directives:

- Gas Appliance Directive (90/396/EEC)
- Low Voltage directive (73/23/EEC)

The fact that the VE series gas valves are certified to European Standard EN161 means that this series meets more stringent requirements than laid down in the essential requirements stated in the directives and therefore meets the requirements in all EC and EFTA countries.

Details can be found in the approvals list. In addition our controls have been certified by DIN-DVGW in Germany.

The registration number specific for each O.S. number is mentioned on the label of the control.

ORDERING INFORMATION

When ordering specify:

- Model number of VE series gas valve required: see model number chart below.
- Order numbers of replacement parts and accessories required, i.e. flanges, compression fittings: see replacement parts/accessories.

Note

Most models of valves, replacement parts and accessories will be available under "TRADELINE" label. Ask your wholesaler for details.

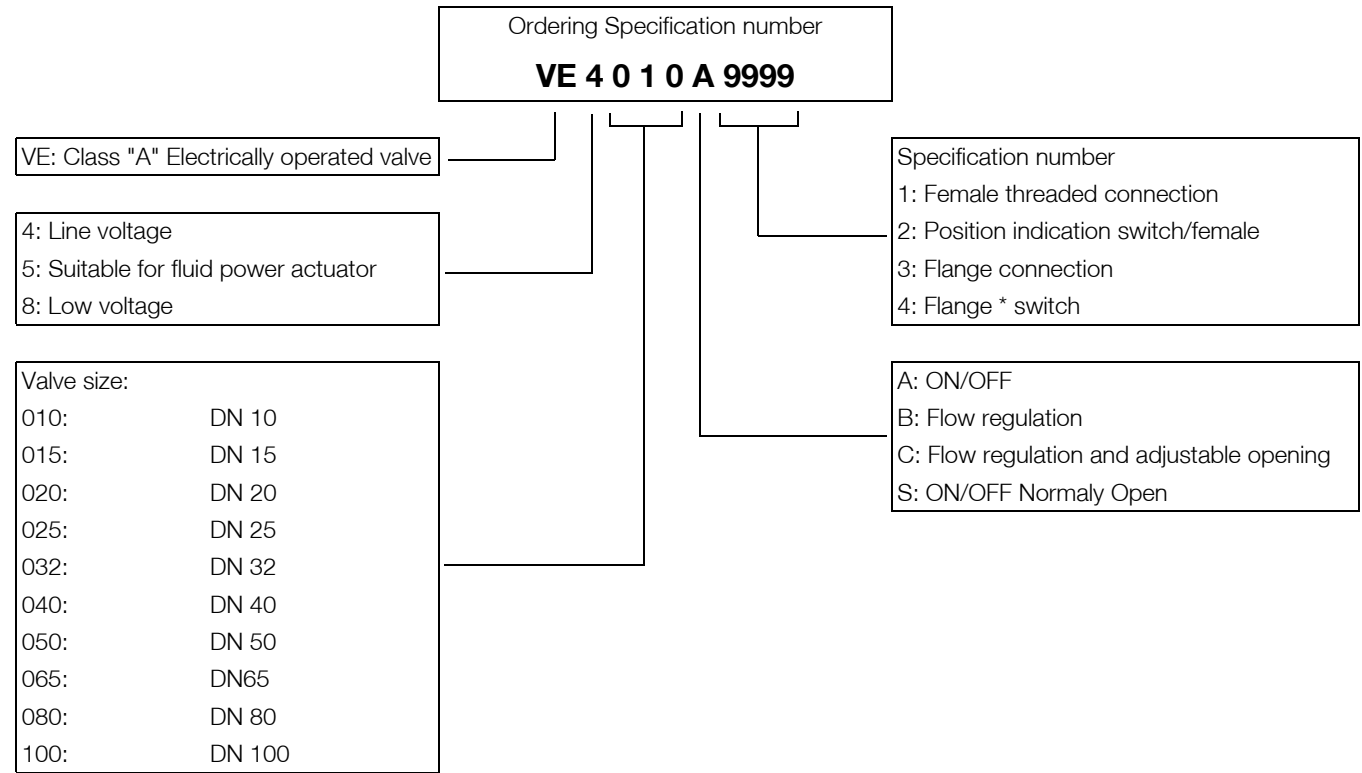

Model number chart

REPLACEMENT PARTS AND ACCESSORIES

Warning

Take care that only qualified persons carry out the installation of parts, accessories, and add on components.

Follow the installation instructions included in the package.

Check that the selected part, accessory or add on component is the correct one for the application in question. Specification of data is given in the instruction leaflet in the package.

Replace the old gaskets with the new ones supplied in the package and check for leakage when the supply is switched on again.

After installation and/or replacement has been completed, a gas leak test must be carried out.

Also check the gas valve for satisfactory operation after fitting accessories.

Coils

Important

When ordering replacement coils include the complete valve O.S. number, in order to provide the coil with proper product identification sticker.

Coil for VE-series	10A- 200-360mbar		
	Voltage		Bobine Standards
	24	ac	BB052401
	24-28	dc	BB052801
	110	ac	BB051101
	220-240	ac	BB052301

Coil for VE-series	10B, C- 200-360mbar		
	Voltage		Bobine Standards
	24	ac	BB152401
	24-28	dc	BB152801
	110	ac	BB151101
	220-240	ac	BB152301

Coil for VE-series	15A- 200-360mbar - IP65		
	Voltage		Bobine Standards
	24	ac	
	24-28	dc	
	110	ac	BB051102
	220-240	ac	BB052302

Coil for VE-series	15B- 200-360mbar - IP65		
	Voltage		Bobine Standards
	24	ac	BB152401
	24-28	dc	BB152804
	110	ac	BB151107
	220-240	ac	BB152305

Coil for VE-series	15A- 200-360mbar		
	Voltage		Bobine Standards
	12	dc	BB051202
	24	ac	BB052401
	24-28	dc	BB052801
	110	ac	BB051101
	220-240	ac	BB052301

Coil for VE-series	20A- 200-360mbar		
	Voltage		Bobine Standards
	12	dc	BB051205
	24	ac	BB052425
	24-28	dc	BB052825
	110	ac	BB051125
	220-240	ac	BB052325

Coil for VE-series	15B,C- 200-360mbar		
	Voltage		Bobine Standards
	24	ac	BB152401
	24-28	dc	BB152801
	110	ac	BB151101
	220-240	ac	BB152301

Coil for VE-series	20B,C- 200-360mbar		
	Voltage		Bobine Standards
	24	ac	BB152425
	24-28	dc	BB152825
	110	ac	BB151125
	220-240	ac	BB152325

Coil for VE-series	20A- 200-360mbar - IP65		
	Voltage		Bobine Standards
	24	ac	
	24-28	dc	
	110	ac	
	220-240	ac	BB052326

Coil for VE-series	25A- 200-360mbar - IP65		
	Voltage		Bobine Standards
	24	ac	
	24-28	dc	
	110	ac	BB051126
	220-240	ac	BB052326

Coil for VE-series	20B- 200-360mbar - IP65		
	Voltage		Bobine Standards
	24	ac	
	24-28	dc	
	110	ac	BB151108
	220-240	ac	BB152324

Coil for VE-series	25B- 200-360mbar - IP65		
	Voltage		Bobine Standards
	24	ac	
	24-28	dc	
	110	ac	BB151108
	220-240	ac	BB152324

Coil for VE-series	20S- 200-360mbar		
	Voltage		Bobine Standards
	24	ac	BB152401
	24-28	dc	BB152801
	110	ac	BB151101
	220-240	ac	BB152302

Coil for VE-series	25C- 200-360mbar - IP65		
	Voltage		Bobine Standards
	12	dc	
	24	ac	
	24-28	dc	
	110	ac	BB151126
	220-240	ac	

Coil for VE-series	20S- 200-360mbar- IP65		
	Voltage		Bobine Standards
	24	ac	
	24-28	dc	
	110	ac	BB151107
	220-240	ac	

Coil for VE-series	25S- 200-360mbar		
	Voltage		Bobine Standards
	24	ac	BB152401
	24-28	dc	BB152801
	110	ac	BB151101
	220-240	ac	BB152302

Coil for VE-series	25A- 200-360mbar		
	Voltage		Bobine Standards
	12	dc	BB051205
	24	ac	BB052425
	24-28	dc	BB052825
	110	ac	BB051125
	220-240	ac	BB052325

Coil for VE-series	32A- 200mbar		
	Voltage		Bobine Standards
	24	ac	BB052432
	24-28	dc	BB052842
	110	ac	BB051133
	220-240	ac	BB052340

Coil for VE-series	25B,C- 200-360mbar		
	Voltage		Bobine Standards
	24	ac	BB152425
	24-28	dc	BB152825
	110	ac	BB151125
	220-240	ac	B152325

Coil for VE-series	32B,C- 200mbar		
	Voltage		Bobine Standards
	24	ac	BB152440
	24-28	dc	BB152840
	110	ac	BB151140
	220-240	ac	BB152326

Coil for VE-series	32A-360mbar		
	Voltage		Bobine Standards
	24	ac	
	24-28	dc	
	110	ac	
	220-240	ac	

Coil for VE-series	32B-360mbar		
	Voltage		Bobine Standards
	24	ac	
	24-28	dc	
	110	ac	BB151103
	220-240	ac	BB152340

Coil for VE-series	32C-360mbar		
	Voltage		Bobine Standards
	24	ac	
	24-28	dc	
	110	ac	
	220-240	ac	BB152340

Coil for VE-series	32A-200mbar - IP65		
	Voltage		Bobine Standards
	24	ac	
	24-28	dc	
	110	ac	BB051140
	220-240	ac	BB052342

Coil for VE-series	32B-360mbar - IP65		
	Voltage		Bobine Standards
	24	ac	
	24-28	dc	
	110	ac	BB151104
	220-240	ac	

Coil for VE-series	40A-200mbar		
	Voltage		Bobine Standards
	24	ac	BB052432
	24-28	dc	BB052842
	110	ac	BB051133
	220-240	ac	BB152340

Coil for VE-series	40B,C-200 mbar		
	Voltage		Bobine Standards
	24	ac	BB152440
	24-28	dc	BB152840
	110	ac	BB151140
	220-240	ac	BB152326

Coil for VE-series	40A-360mbar		
	Voltage		Bobine Standards
	24	ac	
	24-28	dc	
	110	ac	
	220-240	ac	BB052303

Coil for VE-series	40B,C-360mbar		
	Voltage		Bobine Standards
	24	ac	
	24-28	dc	
	110	ac	BB151103
	220-240	ac	BB152340

Coil for VE-series	40A-200mbar - IP65		
	Voltage		Bobine Standards
	24	ac	
	24-28	dc	
	110	ac	BB051140
	220-240	ac	BB052342

Coil for VE-series	40C-200mbar - IP65		
	Voltage		Bobine Standards
	24	ac	
	24-28	dc	
	110	ac	
	220-240	ac	BB152328

Coil for VE-series	40B-360mbar - IP65		
	Voltage		Bobine Standards
	24	ac	
	24-28	dc	
	110	ac	BB151104
	220-240	ac	

Coil for VE-series	50A-200mbar		
	Voltage		Bobine Standards
	24	ac	BB052453
	24-28	dc	BB052802
	110	ac	BB051150
	220-240	ac	BB052303

Coil for VE-series	50B, C-200mbar		
	Voltage		Bobine Standards
	24	ac	
	24-28	dc	BB152803
	110	ac	BB151103
	220-240	ac	BB152340

Coil for VE-series	50A-360mbar		
	Voltage		Bobine Standards
	24	ac	
	24-28	dc	
	110	ac	
	220-240	ac	BB052307

Coil for VE-series	50B,C-360mbar		
	Voltage		Bobine Standards
	24	ac	
	24-28	dc	
	110	ac	BB051152
	220-240	ac	BB152303

Coil for VE-series	50A-200mbar - IP65		
	Voltage		Bobine Standards
	24	ac	
	24-28	dc	
	110	ac	BB051152
	220-240	ac	BB052306

Coil for VE-series	50B-200mbar - IP65		
	Voltage		Bobine Standards
	24	ac	
	24-28	dc	
	110	ac	
	220-240	ac	BB152342

Coil for VE-series	50B-360mbar - IP65		
	Voltage		Bobine Standards
	24	ac	
	24-28	dc	
	110	ac	BB151153
	220-240	ac	BB152307

Coil for VE-series	65A-100-200mbar		
	Voltage		Bobine Standards
	24	ac	
	24-28	dc	
	110	ac	BB051165
	220-240	ac	BB052365

Coil for VE-series	65B-200mbar		
	Voltage		Bobine Standards
	24	ac	
	24-28	dc	BB152466
	110	ac	BB151165
	220-240	ac	BB152365

Coil for VE-series	65B-360mbar		
	Voltage		Bobine Standards
	24	ac	
	24-28	dc	
	110	ac	BB151180
	220-240	ac	BB152380

Coil for VE-series	65B-200mbar - IP65		
	Voltage		Bobine Standards
	24	ac	
	24-28	dc	
	110	ac	BB151167
	220-240	ac	BB152366

Coil for VE-series	80B-200mbar		
	Voltage		Bobine Standards
	24	ac	
	24-28	dc	BB152481
	110	ac	BB151180
	220-240	ac	BB152380

Coil for VE-series	80B-360mbar		
	Voltage		Bobine Standards
	24	ac	
	24-28	dc	
	110	ac	BB151105 (booster)
	220-240	ac	BB152382 (booster)

Coil for VE-series	80B-200mbar - IP65		
	Voltage		Bobine Standards
	24	ac	
	24-28	dc	
	110	ac	BB151181
	220-240	ac	

Coil for VE-series	100B-200mbar - IP65		
	Voltage		Bobine Standards
	24	ac	
	24-28	dc	
	110	ac	BB151100
	220-240	ac	

Coil for VE-series	80B-360mbar - IP65		
	Voltage		Bobine Standards
	24	ac	
	24-28	dc	
	110	ac	
	220-240	ac	BB152383 (booster)

Coil for VE-series	100A-200mbar		
	Voltage		Bobine Standards
	24	ac	
	24-28	dc	
	110	ac	BB151112
	220-240	ac	BB152300

Coil for VE-series	100A-360mbar		
	Voltage		Bobine Standards
	24	ac	
	24-28	dc	
	110	ac	BB151113
	220-240	ac	BB152308

Coil for VE-series	100B-200mbar		
	Voltage		Bobine Standards
	24	ac	
	24-28	dc	
	110	ac	BB151112
	220-240	ac	BB152300

Coil for VE-series	100B-360mbar		
	Voltage		Bobine Standards
	24	ac	
	24-28	dc	
	110	ac	BB151113
	220-240	ac	BB152308