

Honeywell

THE C7012E AND F ARE ELECTRONIC FLAME DETECTORS FOR SENSING THE ULTRAVIOLET RADIATION GENERATED BY THE COMBUSTION OF GAS, OIL, PULVERIZED COAL, OR OTHER FUELS.

- C7012E,F detectors are designed for use with self-checking flame safeguard controls such as the R4138A,B, R4075B, R4181A, and controls which use the R7253B and R7247C Dynamic Self Check Amplifiers.
- An oscillating shutter in the C7012E,F interrupts the line of sight of the detector 60 to 120 times a minute to check the detector circuit. Any malfunction results in a safety shutdown.
- Threaded conduit fitting and color-coded leadwires provide rapid electrical hookup.
- A quartz viewing window or magnifying lens (rated at 20 psi [137.9 kPa]) in the C7012E mounting flange prevents high temperature gases, dust, or moisture from entering the detector housing.
- A high pressure window (rated at 50 psi [344.7 kPa]) is available as an accessory for the C7012E.
- Heat block is built into the C7012E mounting flange.
- Model with magnifying lens (increases the ultraviolet light the detector senses) is available.
- Swivel mount is available for C7012E or F.
- Antivibration mount is available for C7012E.
- C7012E meets NEMA 4 (water- and dust-tight) specifications.
- The C7012F has an explosion-proof housing for use in hazardous atmospheres.
- The window in the C7012F is rated at 100 psi [689.5 kPa].

PURPLE PEEPER ULTRAVIOLET FLAME DETECTORS

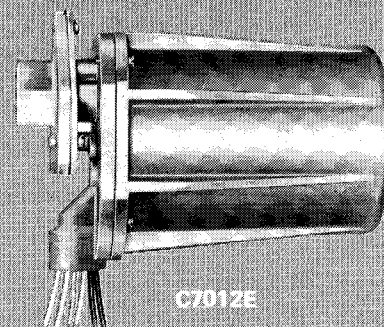

C7012E

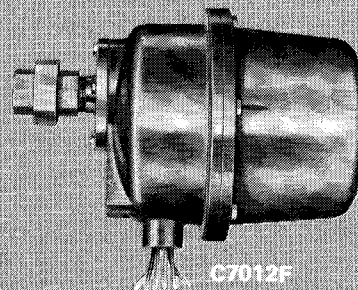

C7012F

C7012E,F

SPECIFICATIONS

IMPORTANT

THE SPECIFICATIONS GIVEN IN THIS PUBLICATION DO NOT INCLUDE NORMAL MANUFACTURING TOLERANCES. THEREFORE, THIS UNIT MAY NOT MATCH THE LISTED SPECIFICATIONS EXACTLY. ALSO, THIS PRODUCT IS TESTED AND CALIBRATED UNDER CLOSELY CONTROLLED CONDITIONS, AND SOME MINOR DIFFERENCES IN PERFORMANCE CAN BE EXPECTED IF THOSE CONDITIONS ARE CHANGED.

MODELS:

C7012E Purple Peeper Ultraviolet Flame Detector—for use with R4138A,B, R4075B, R4181A self-checking flame safeguard controls, and controls which use R7253B and R7247C Dynamic Self Check Amplifiers.

C7012F Purple Peeper Ultraviolet Flame Detector—same as C7012E except with explosion-proof case for use in hazardous atmospheres.

ELECTRICAL RATINGS:

Voltage and Frequency (power supply required for internal amplifier and shutter)—

C7012E—

Internal amplifier—separate models for 120, 208, or 240 volts ac, each suitable for operation at 50 or 60 Hz; 1 model for 220 volts ac, 50 Hz.

Shutter—the shutter leads (white) must be connected to 120 volts.

C7012F (internal amplifier and shutter)—120 volts ac, 50/60 Hz.

Power Consumption—

C7012E—14.3 watts at 60 Hz max.

C7012F—13.7 watts at 60 Hz max.

AMBIENT TEMPERATURE RATING: Minus 20 F [minus 29 C] to plus 125 F [plus 52 C], outside the case.

MAXIMUM FACEPLATE TEMPERATURE: 172 F [78 C] in 125 F [52 C] ambient.

NOTE: The faceplate is the surface of the detector housing behind the mounting flange or union and including the conduit fitting (Figs. 1 and 2).

PRESSURE RATING OF QUARTZ WINDOW:

C7012E—window, 20 psi [137.9 kPa] rating. Model with magnifying lens (20 psi [137.9 kPa] rating) is available.

C7012F—window, 100 psi [689.5 kPa] rating.

HOUSING:

C7012E—cast-aluminum cover; separate plate and cast-aluminum flange act as heat block and seal-off. Meets NEMA 4 (water- and dust-tight) specifications.

C7012F—explosion-proof, 2-piece, cast-aluminum.

MOUNTING MEANS:

C7012E—mounting flange threaded for 3/4 or 1 inch NPT sighting pipe, depending on model.

C7012F—incorporates both a 1 inch pipe flange and a 1 inch union for connection to a sighting pipe.

WIRING CONNECTIONS:

C7012E—six NEC Class 1 color-coded leadwires, length 8 feet [2.4 metres]. (A model with 25 foot [7.6 metre] leads is available.) Faceplate has threaded fitting for 1/2 inch flexible conduit.

C7012F—six NEC Class 1 color-coded leadwires, length 5 feet [1.5 metres]. (A model with 25 foot [7.6 metre] leads is available.) Faceplate has threaded fitting for 1/2 inch pipe.

WEIGHT:

C7012E—approximately 3-3/4 pounds [1.7 kilograms].

C7012F—approximately 14-1/4 pounds [6.4 kilograms].

DIMENSIONS: See Figs. 1 and 2.

APPROVALS:

UNDERWRITERS LABORATORIES INC. LISTED:

C7012E—120 volt models only; File No. MP268, Guide No. MCCZ.

C7012F—for use in hazardous locations, Class I, Groups C and D, and Class II, Groups E,F, and G; File No. E34649, Guide No. ZTSZ.

(continued on page 3)

ORDERING INFORMATION

WHEN PURCHASING REPLACEMENT AND MODERNIZATION PRODUCTS FROM YOUR TRADELINE WHOLESALE OR YOUR DISTRIBUTOR, REFER TO THE TRADELINE CATALOG OR PRICE SHEETS FOR COMPLETE ORDERING NUMBER, OR SPECIFY—

1. Order number (specify C7012E with magnifying lens, or with 1 inch NPT mounting hole if desired).
2. Voltage and frequency.
3. Leadwire length, if 25 ft. [7.6 M] leads are desired.
4. Replacement parts, if desired.
5. Accessories, if desired.

IF YOU HAVE ADDITIONAL QUESTIONS, NEED FURTHER INFORMATION, OR WOULD LIKE TO COMMENT ON OUR PRODUCTS OR SERVICES, PLEASE WRITE OR PHONE:

1. YOUR LOCAL HONEYWELL RESIDENTIAL DIVISION SALES OFFICE (CHECK WHITE PAGES OF PHONE DIRECTORY).

2. RESIDENTIAL DIVISION CUSTOMER SERVICE
HONEYWELL INC., 1885 DOUGLAS DRIVE NORTH
MINNEAPOLIS, MINNESOTA 55422 (612) 542-7500

(IN CANADA—HONEYWELL CONTROLS LIMITED, 740 ELLESMERE ROAD, SCARBOROUGH, ONTARIO M1P 2V9)
INTERNATIONAL SALES AND SERVICE OFFICES IN ALL PRINCIPAL CITIES OF THE WORLD.

CANADIAN STANDARDS ASSOCIATION CERTIFIED: C7012E, 120 volt models only; File No. LR1620.

FACTORY MUTUAL APPROVED: C7012E, Report No. 14740.

REPLACEMENT PARTS:

All models—

- 113236 Electron Tube.
- 115330 Electron Tube.
- 113228 Ultraviolet Sensing Tube.
- 191286 Ultraviolet Sensing Tube.
- 190971D Coil and Shutter Assembly for 220V, 50 Hz models only.
- 190971B Coil and Shutter Assembly for all other models.

C7012E only—

- 114372 Quartz Viewing Window, rated for 20 psi [137.9 kPa].
- 124204 Quartz Magnifying Lens, rated for 20 psi [137.9 kPa].
- 114465 Gasket, silicone rubber; for installing viewing window (3 required).
- 120739 Gasket, asbestos-neoprene; heat insulation and seal-off for mounting flange.

C7012F only—

- 122037 Quartz Viewing Window, rated for 100 psi [689.5 kPa].

ACCESSORIES:

All models—

7616BV Bag Assembly; includes 118373 Pipe Tee, galvanized iron, with 3 female connections (3/4, 3/4, and 1/4 inch NPT internal threads), and 132588 Pipe Nipple, galvanized iron, with 3/4 inch NPT external threads on both ends. For connecting an air supply to ventilate the sighting pipe. Can be used with or without the swivel mount.

118369 Bushing, galvanized iron, with 3/4 inch NPT internal threads on one end and 1 inch NPT external threads on the other end. For adapting a detector with 1 inch NPT internal threads (for mounting) to a 3/4 inch sighting pipe, or to the pipe nipple and tee in the 7616BV Bag Assembly for connecting an air supply.

118367A Swivel Mount.

130716A Autotransformer—120V primary, 135V secondary. Provides extra power for shutter operation when the detector is mounted vertically, or within 45 degrees of vertical. Dimensions of the autotransformer are shown in Fig. 3.

W136A Test Meter (includes 117053 Meter Connector Plug).

117053 Meter Connector Plug (for older W136A models).

C7012E only—

- 122748 Quartz Viewing Window, rated for 50 psi [344.7 kPa].
- 124204 Quartz Magnifying Lens, rated for 20 psi [137.9 kPa]; for increasing the ultraviolet radiation sensed by the detector.

120934 Mounting Flange, aluminum, with 3/4 inch NPT internal threads for attaching to sighting pipe.

124198 Mounting Flange, aluminum, with 1 inch NPT internal threads for attaching to sighting pipe.

123539 Antivibration Mount.

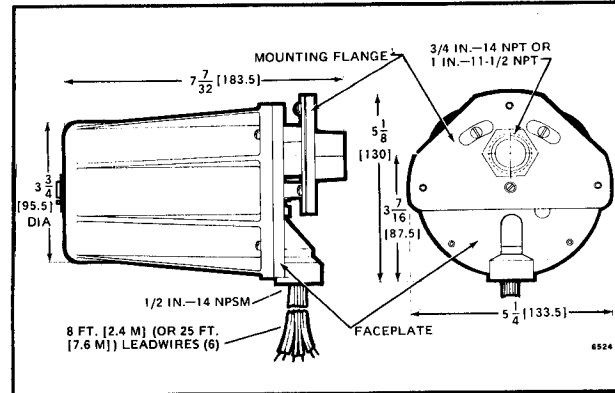

FIG. 1—DIMENSIONS IN INCHES [MILLIMETRES SHOWN IN BRACKETS] OF THE C7012E.

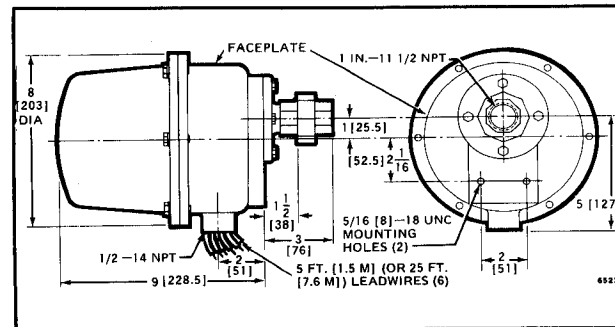

FIG. 2—DIMENSIONS IN INCHES [MILLIMETRES SHOWN IN BRACKETS] OF THE C7012F.

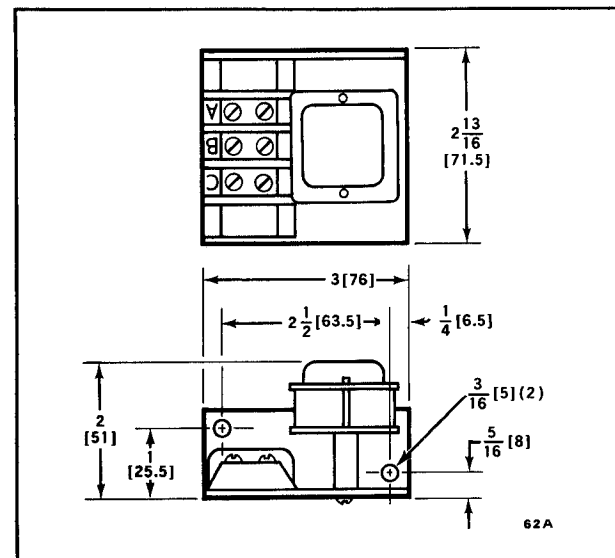

FIG. 3—DIMENSIONS IN INCHES [MILLIMETRES SHOWN IN BRACKETS] OF THE 130716A AUTOTRANSFORMER.

PLANNING THE INSTALLATION

Follow the burner manufacturer's instructions, if provided, when installing the C7012E or F. If the manufacturer has not provided detailed instructions, follow the general instructions below.

BASIC REQUIREMENTS FOR UV DETECTORS

All flames produce ultraviolet radiation. The UV (ultraviolet) detector takes advantage of this fact to prove the presence or absence of flame.

When the detector is exposed to ultraviolet radiation, a signal is passed to the amplifier section of the flame safeguard control, where it is amplified and used to trigger the flame relay. Since it is necessary for the detector to actually see the flame, it is best to locate the detector as close to the flame as physical arrangement and temperature restrictions will permit.

Sighting requirements for an ultraviolet detector are as follows.

1. For pilot flame only—sighting must be along the long axis of the pilot flame as close as possible to the point at which the flame becomes too small to ignite the main burner.

2. Main flame only—sighting line must be at the most stable part of the flame for all firing rates. Some burners may require two detectors in parallel to prove both high and low firing.

3. For both pilot and main flame—sighting must be at the junction of the 2 flames.

RADIATION SOURCES (OTHER THAN FLAME) SENSED BY THE UV DETECTOR

The UV detector is sensitive to all sources of ultraviolet radiation. It is, in addition, somewhat less sensitive to X-rays and to gamma rays. Sources of radiation other than the flame do not normally cause difficulty, with the exception of ignition spark.

IMPORTANT

THE DETECTOR WILL RESPOND TO IGNITION SPARK. AIM DETECTOR SO THE SPARK IS NOT SIGHTED.

The following list includes sources of ultraviolet, X-ray, and gamma ray radiation that could trigger the UV detector:

Hot refractory, above 2500 F [1371 C].

Spark—

- ignition transformers.
- welding arcs.
- lightning.

Bright incandescent or fluorescent artificial light.
Solar radiation ("daylight").

Bright flashlight held close to the sensing tube and aimed at its sensitive region.

Gas lasers.

Sun lamps.

Germicidal lamps.

Diffraction analyzers.

Electron microscopes.

Radiographic X-ray machines.

High-voltage vacuum switches and condensers.

Defective television sets.

Radioisotopes.

These sources usually do not cause problems in flame safeguard systems, but the installer should be aware of them when installing or maintaining the detectors.

SPECIFIC REQUIREMENTS OF THE C7012E AND F

The C7012 is mounted outside the combustion chamber. The mounting flange or union is screwed to one end of sighting pipe inserted through the furnace wall. The UV cell in the C7012 sights the flame through the sighting pipe.

TEMPERATURE RANGES

The ambient temperature at the detector case must be within the range minus 20 F [minus 29 C] to plus 125 F [plus 52 C]. Higher or lower temperatures may affect the condition of certain internal components such as the electrolytic capacitor and rectifier.

If the ambient temperature at the case is 125 F [52 C], the maximum allowable temperature at the faceplate is 172 F [78 C]. The faceplate is the surface of the detector housing behind the mounting flange or union and including the conduit fitting (Figs. 1 and 2). If conditions result in more heat than this at the faceplate, some means must be devised to shield or insulate the detector. See section on Faceplate Temperature, page 10, for suggested methods.

POSITION OF C7012E OR F

The C7012E or F must be positioned so that the arrow on the label on the base is vertical and pointing downward (Fig. 4). This position must be maintained during operation for correct shutter action. However, the sighting axis may be at any angle from horizontal to 45 degrees. If mounting location requires that the C7012E or F sighting axis exceeds 45 degrees from horizontal, or the arrow cannot be vertical and pointed downward, use the 130716A Autotransformer to supply the voltage (135V) to the shutter to make certain it operates smoothly. See the transformer mounting procedures below, under INSTALLATION. See Fig. 7, 9, 11, 13, or 15 for wiring hookup.

Generally, it is desirable to have the C7012E or F and sighting pipe tilted downward to prevent soot buildup in pipe or on the quartz flame viewing window of detector.

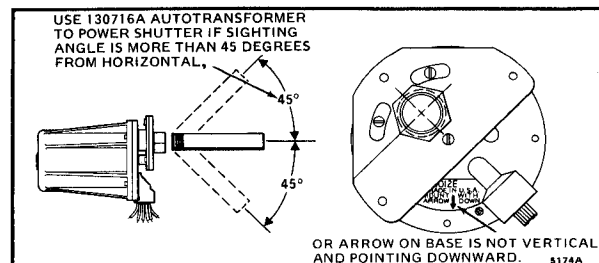

FIG. 4-CORRECT MOUNTING POSITION.

PLAN LOCATION OF SIGHTING PIPE

The location of the sighting pipe is the most critical part of the installation, since the detector output current depends on the correct sighting of a steady flame only. Since no 2 situations are likely to be identical, the location, length, size, and sighting angle of the pipe must be determined by the burner manufacturer or at the time and place of installation.

Review carefully the requirements of the particular job, and select the best location for the sighting pipe:

1. Detector must have a completely unobstructed view of whichever flame is to be proven (Fig. 5).

2. Sighting pipe must allow only a steady portion of the flame to be seen by detector. Flame must not roll, rotate, or float away from detector's view.

3. Electric ignition sparks must not be sighted by detector.

4. Detector must not sight through a flame on refractory over 2500 F [1371 C].

INSTALLATION

CAUTION

1. Do not connect these detectors to non-Honeywell manufactured flame safeguard controls (primaries, programmers, multiburner systems, burner management systems, etc.) as it could be unsafe.
2. Installer must be a trained, experienced flame safeguard control service technician.
3. Disconnect power supply before beginning installation to prevent electrical shock and equipment damage.
4. All wiring must comply with applicable local electrical codes, ordinances, and regulations.
5. Voltage and frequency of the power supply connected to this device must agree with those marked on the device. The shutter leads (white) must be connected to 120 volts (135 volts when the autotransformer is used) only.
6. Perform all required checkout tests after installation is complete.

Proper flame detector installation is the basis of a good flame safeguard installation. Refer to the burner manufacturer's instructions as well as to the following instructions. Follow instructions carefully to make the best possible application of the flame detector.

SIGHTING PIPE INSTALLATION

PREPARE HOLE IN FURNACE WALL

Punch or drill hole for sighting pipe in burner wall at the selected location. Hole should be sized for at least a 1-1/2 in. [38 mm] pipe diameter. Sighting pipes of 2 to 3 in. [50 to 76 mm] diameter produce better results for horizontal rotary burners, which require wide viewing angles.

Flare the hole to give room for small adjustments of the sighting angle. For large diameter pipe, the taper of the hole should be about 1 in. [25 mm] for every 3 in. [76 mm] of furnace wall thickness.

INSTALL SIGHTING PIPE

Thread one end of a piece of black iron pipe of a suitable diameter and cut it to the desired length (as short as practicable). Do not use stainless steel or galvanized pipe because they reflect light internally and complicate aiming the pipe. Tack weld the pipe to the boiler plate in a trial position. Do not weld in

place until satisfactory operation is proved. If the sighting pipe is greater than 45 degrees from the horizontal (Fig. 4), use a 130716A Autotransformer to power the C7012 shutter.

IMPORTANT

DO NOT weld the sighting pipe in place until after completing the **ADJUSTMENTS AND CHECKOUT** beginning on page 9.

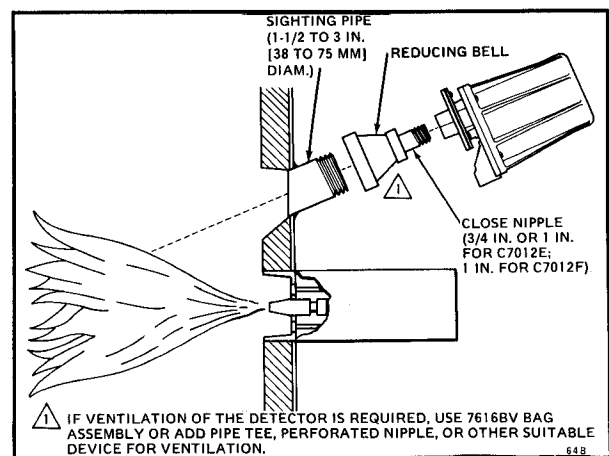

FIG. 5—TYPICAL MOUNTING OF THE C7012E,F.

ADD PIPE FITTINGS

Install a reducing bell and a close nipple as shown in Fig. 5. The C7012E requires a 3/4 or 1 inch close nipple; the C7012F, a 1 inch nipple.

When using 118367A Swivel Mount, see Honeywell instruction sheet, form 60-0361.

SIGHTING PIPE VENTILATION FOR OIL FLAMES

Ventilate the sighting pipe in oil systems where vapors or oil mist may impede the detector's view of the flame. A good method for negative pressure combustion chambers is to drill a couple of small holes in the external portion of the sighting pipe. For positive pressure burners, tap the sighting pipe, use 7616BV or install a pipe tee, and provide a supply of pressurized air from the burner blower.

FLAME DETECTOR INSTALLATION

MOUNT THE DETECTOR

Mount the C7012 so that the arrow on the label on the base is vertical and pointing downward (Fig. 4). If the C7012 cannot be mounted in this position, use a 130716A Autotransformer to power the shutter.

VIBRATION

The detector will withstand normal burner vibrations. For applications where the vibration is excessive, however, a special shock mounting, Part No. 123539, is available for the C7012E. If the shock mount is used, all tests for position and sighting should be made with the mount in place.

MOUNT 130716A AUTOTRANSFORMER

Mounting the C7012E or F with its sighting axis within 45 degrees of vertical, or with the arrow on its base not pointing directly downward (Fig. 4), requires 135 volts to operate the shutter properly. A 130716A Autotransformer provides the correct voltage. However, it can only be used with 120 volt flame safeguard controls as it overloads the internal transformer on 208, 220, and 240 volt models and causes excessive heating.

IMPORTANT

The C7012 flame detector can be mounted with its sighting axis within 45 degrees of vertical, or with the arrow on its base not pointing directly downward, only when using a 120 volt model flame safeguard control. The required 130716A Autotransformer operates only on 120 volts, 50/60 Hz.

1. Locate the transformer at the burner installation near the C7012E or F for convenient wiring.
2. At the selected location, using the transformer chassis as a template, mark and drill the 3/16 in. [4.8 mm] mounting holes.
3. Using the furnished screws through the mounting holes, attach the transformer to the burner.

WIRING (FIGS. 6-15)

CAUTION

When using a C7012E or F with an R7247C Plug-in Flame Signal Amplifier, be careful not to short the WHITE shutter leadwires together (by wiring incorrectly, leaving an incorrect jumper wire, or stripping the insulation too far so the bare leadwires can touch). If the shutter leadwires are shorted during operation, the amplifier will be destroyed.

1. All wiring must comply with applicable electrical codes, ordinances, and regulations. Use NEC Class 1 wiring.
2. Keep the flame signal leadwires from the flame detector to the terminal strip or wiring subbase as short as possible. Capacitance increases with leadwire length, reducing the signal strength. The maximum permissible leadwire length depends on the type of leadwire and conduit type and diameter. The ultimate limiting factor in flame signal leadwire length is the signal current. Refer to Table I in the ADJUSTMENTS AND CHECK-OUT section.
3. The detector comes with color-coded, plastic-insulated, No. 18 leadwires, 8 feet [2.4 metres] long,

rated for 221 F [105 C]. (Some models have 25 foot [7.6 metre] leadwires.) These wires must be run in a conduit.

4. If the leadwires aren't long enough to reach the terminal strip or wiring subbase, make the required splices in a junction box.

5. If splicing is necessary, use moisture-resistant No. 14 wire suitable for at least 167 F [75 C] if the detector is used with a flame safeguard primary control, or at least 194 F [90 C] if used with a flame safeguard programming control.

6. For high temperature installations, use Honeywell Spec. No. R1298020 or equivalent for the "F" leadwire. (This wire is rated up to 400 F [204 C] for continuous duty. It is tested for operation up to 600 volts and breakdown up to 7500 volts.) For the other leadwires, use moisture-resistant No. 14 wire selected for a temperature rating above the maximum operating temperature.

7. Refer to Figs. 6 through 15 for wiring connections.

IMPORTANT

Do not run the flame detector wiring in the same conduit with high voltage ignition transformer wires.

CONNECTING DETECTORS IN PARALLEL

For flames that are difficult to sight, using two parallel C7012E or F Flame Detectors will reduce nuisance shutdowns. If only one of the parallel detectors loses the flame signal, the other will still indicate the flame's presence and will keep the system running. A flame simulating failure in either detector will not allow the system to start up.

Two sources of power must be provided for the C7012E,F. The power to the black leads may be 120, 208, 220, or 240V ac, depending on the model of the detector. The power to the white leads must be 120V ac; this is the power supply for the operation of the shutter. This 120V power is provided by an internal transformer in the flame safeguard control unless the flame safeguard control supply voltage is also 120V, in which case the white leads are fed directly from the line power supply through switching action within the programmer. Consult installation sheet for the flame safeguard control involved.

Two C7012E,F detectors may be wired in parallel to the same terminals on 120 volt flame safeguard controls. On 208, 220, or 240 volt models, two detectors cannot be powered from the internal flame safeguard control transformer without danger of overheating. Therefore, only one C7012E can be used with 208, 220, or 240 volt models.

IMPORTANT

1. Voltage rating of the C7012 must match the power supply of the flame safeguard control.
2. To avoid exceeding the rating of the shutter switch, do not connect more than two C7012E,F Flame Detectors in parallel.
3. Do not use more than one C7012E with 208, 220, or 240 volt models of the flame safeguard control.

**WIRING DIAGRAMS FOR R4138 AND R4181
SELF-CHECKING FLAME SAFEGUARD CONTROLS**

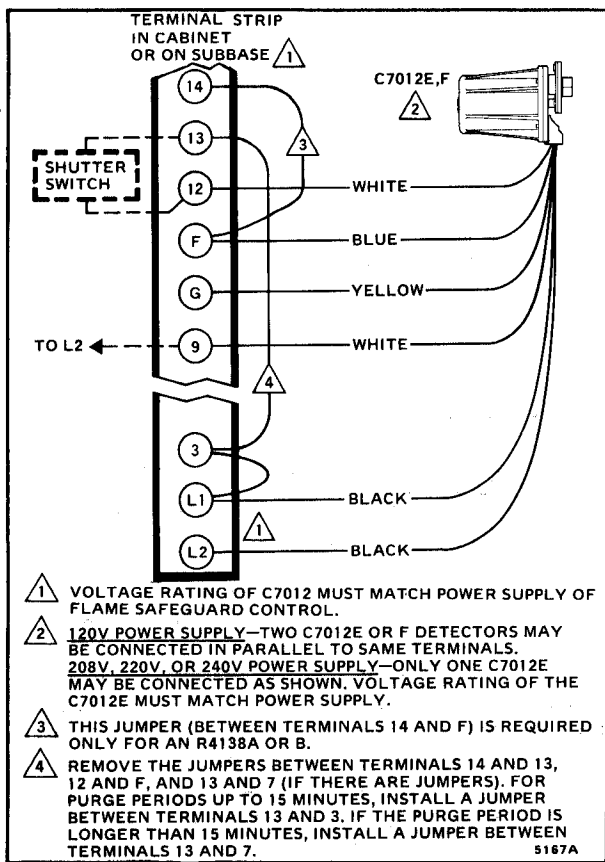

FIG. 6—WIRING DIAGRAM FOR ALL MODELS OF THE R4138; SIGHTING AXIS WITHIN 45 DEGREES OF HORIZONTAL.

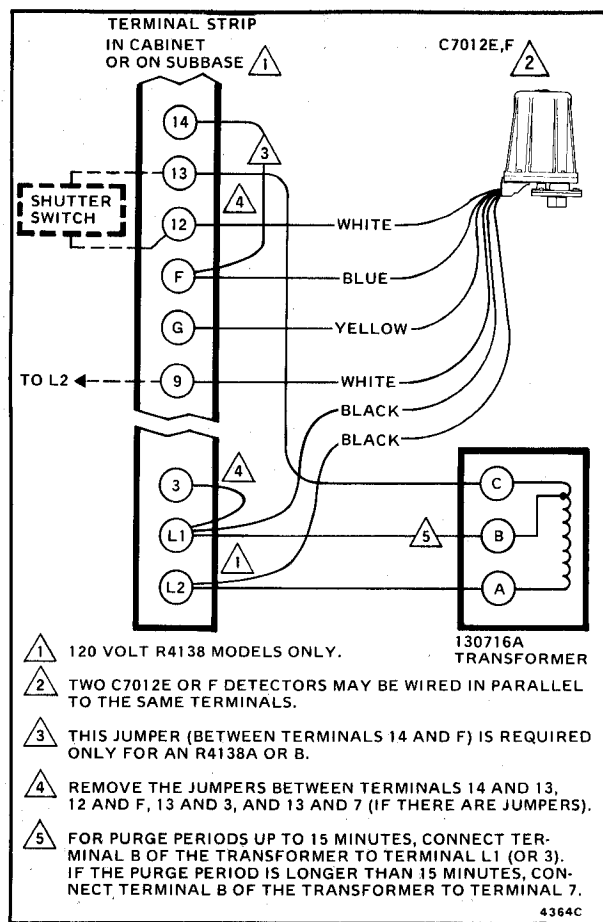

FIG. 7—WIRING DIAGRAM FOR 120 VOLT MODELS OF THE R4138; SIGHTING AXIS WITHIN 45 DEGREES OF VERTICAL.

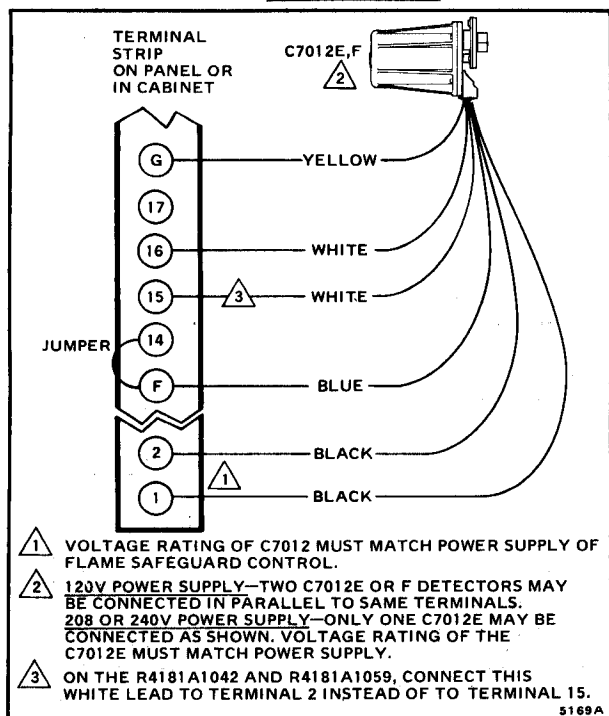

FIG. 8—WIRING DIAGRAM FOR ALL MODELS OF THE R4181; SIGHTING AXIS WITHIN 45 DEGREES OF HORIZONTAL.

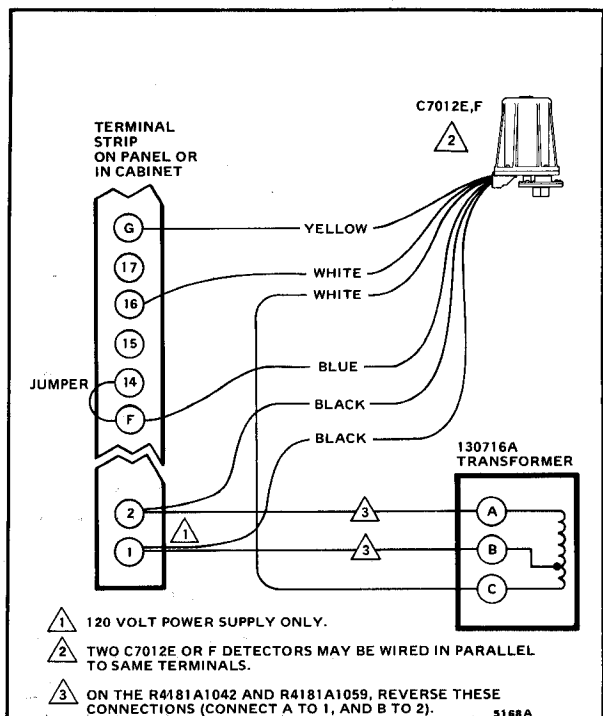

FIG. 9—WIRING DIAGRAM FOR 120 VOLT MODELS OF THE R4181; SIGHTING AXIS WITHIN 45 DEGREES OF VERTICAL.

**WIRING DIAGRAMS FOR R4140
FLAME SAFEGUARD PROGRAMMING CONTROLS**

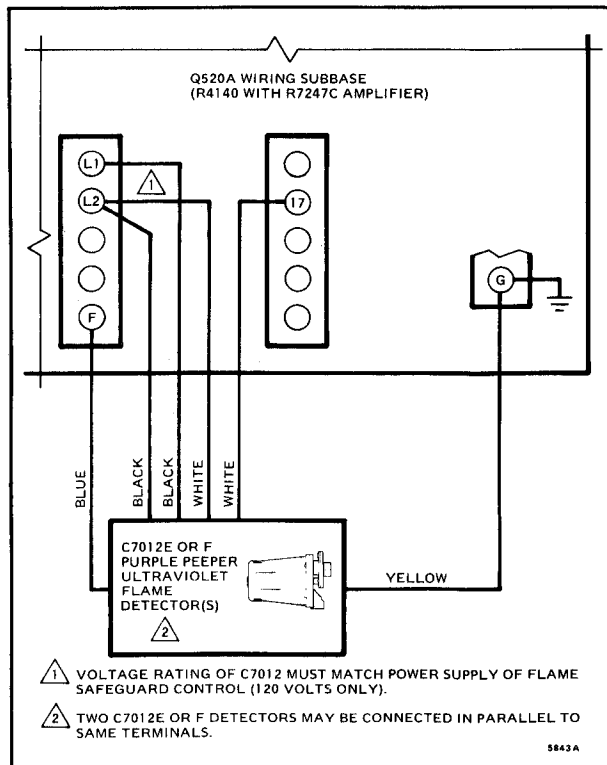

FIG. 14—WIRING DIAGRAM FOR 120 VOLT MODELS OF THE R4140 WITH R7247C AMPLIFIER; SIGHTING AXIS WITHIN 45 DEGREES OF HORIZONTAL.

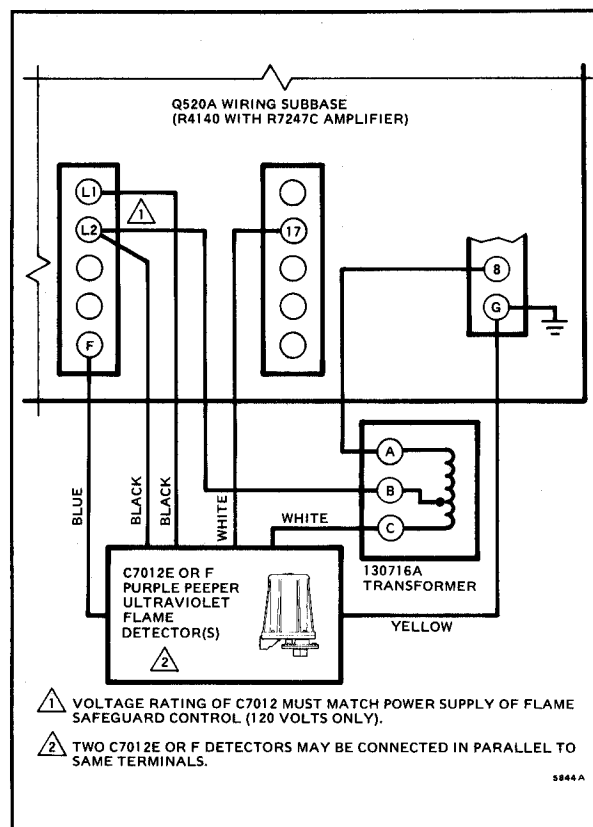

FIG. 15—WIRING DIAGRAM FOR 120 VOLT MODELS OF THE R4140 WITH R7247C AMPLIFIER; SIGHTING AXIS WITHIN 45 DEGREES OF VERTICAL.

ADJUSTMENTS AND CHECKOUT

RUNAWAY SENSING TUBE TEST

NOTE: For initial burner lightoff, consult the burner manufacturer's instructions or the instruction sheet for the flame safeguard control.

During the initial burner lightoff, make sure the flame safeguard control starts (i.e., the load relay, usually 1K, pulls in). If it does not start, check the sensing tube in the ultraviolet detector. If the tube is glowing all the time when no flame is present, replace the sensing tube.

ADJUST DETECTOR SIGHTING POSITION

With the detector installed and the burner(s) running, adjust the position of the detector for optimum flame signal. Read the flame signal in microamps at the meter jack on the plug-in flame signal amplifier or on the flame safeguard control (Fig. 16). Use a microammeter with a 0 to 25 microamp dc range, such as a Honeywell W136A, which has a plug for inserting into the meter jack. (A 117053 Meter Connector Plug may be ordered separately if needed.) Connect the RED (+) meter lead to the red spade tip and the BLACK (-) lead to the black spade tip before inserting the plug into the meter jack.

NOTES:

1. If using an R7247C DYNAMIC SELF CHECK Amplifier, set the selector switch on the Test Meter to the SPL (damped) position. Allow a few seconds for the current to stabilize. The red flame indicating lamp on the amplifier should blink about 1 to 2 times a second (from bright to dim). If the lamp is ON or OFF continuously while reading the flame signal, replace the amplifier.
2. If using an R7253B DYNAMIC SELF CHECK Amplifier, or an R4138A or B or R4181 Self-checking Flame Safeguard Control, depress the TEST button (on the amplifier or on the control) while making a measurement to stabilize the current reading. (The green flame indicating lamp on the R7253B Amplifier should be ON continuously while reading the flame signal.)
3. On a C7012E or F, the shutter operation causes fluctuations in the current reading. Read the average stable current, disregarding the peaks.
4. The flame signal must be steady (or stable as described in Note 3).

(continued on page 10)

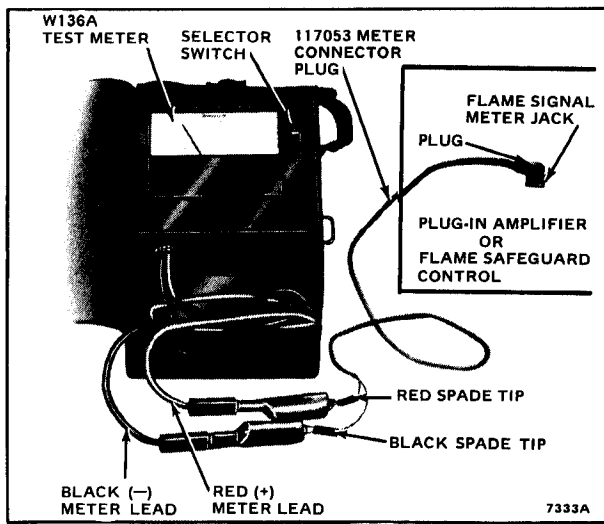

FIG. 16—MEASURING THE FLAME SIGNAL.

Move the detector and sighting pipe around to sight the flame at various positions and angles. Try to get a maximum steady (or stable) reading on the meter. The signal must be above the minimum acceptable current listed in Table I below.

Measure the flame signal for the pilot alone, the main burner flame alone, and both together (unless monitoring only the pilot flame when using an intermittent pilot, or only the main burner flame when using direct spark ignition). Also measure the flame signal at high and low firing rates and while modulating in between (as applicable). With the detector in its final position, all required flame signals must be steady (or stable) and as specified in Table I. If you cannot obtain the proper signal(s), refer to the TROUBLESHOOTING section.

TABLE I—FLAME SIGNAL

| PLUG-IN FLAME SIGNAL AMPLIFIER (GREEN) | FLAME SAFEGUARD CONTROL(S) | MINIMUM ACCEPTABLE STEADY CURRENT (MICROAMPS) | MAXIMUM CURRENT EXPECTED (MICROAMPS) |
|---|---|---|--------------------------------------|
| R7247C ^a (Dynamic Self Check) | R4075C,D,E; R4138C,D; R4140 | 2 | 7 |
| R7253B ^b (Dynamic Self Check) | R4126, R4127, R4150 (with 137738AA Adaptor) | 5 | 14 |
| None | R4075B | 8 | 15 |
| | R4138A,B ^b | 8 | 15 |
| | R4181 ^b | 8 | 15 |

^aSet selector switch on test meter to "SPL" (damped) position to read current.

^bDepress "TEST" button while reading current.

FACEPLATE TEMPERATURE

Operate system until temperatures have stabilized. Check temperature at faceplate of C7012. The faceplate is the surface of the detector housing behind the mounting flange or union and including the conduit fitting (Figs. 1 and 2). If it is 172 F [78 C] or over, devise some means of insulation. Possible arrangements might be:

1. Shield or screen between burner wall and faceplate to reflect radiated heat.
2. Perforated pipe nipple between pipe and mounting flange (for negative pressure combustion chambers).
3. Pipe tee with forced air supply between pipe and mounting flange.

PILOT TURNDOWN TEST

If the detector is used to prove a pilot flame before the main fuel valve(s) can be opened, perform a Pilot Turndown Test before welding the sighting pipe in position. Follow the procedures given in the instruction sheet for the appropriate flame safeguard control, and in the burner manufacturer's instructions.

ULTRAVIOLET RESPONSE TESTS

IGNITION SPARK RESPONSE TEST

Test to make certain that ignition spark is not actuating the flame relay (usually 2K) in the flame safeguard control.

1. Close the pilot and main burner manual shutoff valves.
2. Start the burner and run through the ignition period. Ignition spark should occur, but the flame relay must not pull in. The flame signal should not be more than 1/4 microamp.
3. If the flame relay does pull in, resight the detector farther out from the spark, or away from possible reflection. It may be necessary to construct a barrier to block the ignition spark from the detector's view. Continue adjustments until the flame signal due to ignition spark is less than 1/4 microamp.

RESPONSE TO OTHER ULTRAVIOLET SOURCES

Some sources of artificial light produce small amounts of ultraviolet radiation. Under certain conditions, an ultraviolet detector will respond to them as if it is sensing a flame. **DO NOT USE AN ARTIFICIAL LIGHT SOURCE TO CHECK THE RESPONSE OF AN ULTRAVIOLET DETECTOR.** To check for proper detector operation, flame failure response tests should be conducted under all operating conditions.

WELD THE SIGHTING PIPE

When the flame signal is acceptable after all adjustments have been made, remove the detector and weld the sighting pipe in its final position. (If you are using a swivel mount, the pipe may already be welded.) Then reinstall the detector.

FINAL CHECKOUT

Before putting the burner into service, check out the installation using the procedures in the CHECKOUT section of the instruction sheet for the appropriate flame safeguard control. After completing the checkout, run the burner through at least 1 complete cycle to verify proper operation.

CAUTION

Do not put the system into operation until all tests in the CHECKOUT section of the instruction sheet for the appropriate flame safeguard control, and any others specified in the burner installation instructions, have been satisfactorily completed.

TROUBLESHOOTING

CAUTION

1. Use utmost care while troubleshooting the detector; line voltage is present on some of the terminals when power is on.
2. Open the master switch to disconnect power before removing or installing the detector or its cover.

EQUIPMENT REQUIRED

1. Voltmeter (Honeywell W136A or equivalent)—with 0 to 300 volt ac scale.
2. Microammeter (Honeywell W136A or equivalent)—with 0 to 25 microamp range and SPL scale with damping.
3. Meter connector plug—Part No. 117053 or equivalent (required for some meters).
4. Replacement parts—see SPECIFICATIONS section.

RUNAWAY SENSING TUBE

If the flame safeguard control fails to start on a call for heat (i.e., the load relay, usually 1K, fails to pull in), check the sensing tube in the ultraviolet detector. If the tube is glowing all the time when no flame is present, replace the sensing tube.

UNSATISFACTORY FLAME SIGNAL

If you can't obtain a satisfactory flame signal while adjusting the sighting position of the detector, follow these procedures. If you encounter other problems in the system, refer to the TROUBLESHOOTING section in the instruction sheet for the appropriate flame safeguard control.

NOTE: Instructions for replacing the electron tubes, ultraviolet sensing tube, and quartz viewing window are given in the following SERVICE section.

SYSTEM CHECK

Start burner system and observe sequence. If burner ignites, but flame safeguard control fails to hold in:

1. C7012E—remove C7012E from its mounting flange by loosening 3 screws and rotating case away from flange. C7012F—unscrew pipe union and detach unit.
2. With flame safeguard control energized, hold a lighted match or other source of flame in front of C7012 viewing window.
3. If the flame relay in the control pulls in, the C7012 is functioning properly. If not, look for a dirty quartz window or sighting pipe, or a misaligned sighting pipe. Measure the flame signal as described in the previous ADJUSTMENTS AND CHECKOUT section (see Fig. 16).
4. If flame relay still does not pull in after cleaning quartz window and sighting pipe, or realigning sighting pipe, proceed with C7012 check.

C7012 CHECK

1. With voltmeter scale on W136, check for line voltage between power terminals supplying detector.
2. Remove the cover. With flame safeguard control energized, visually check the 113236 and 115330 Electron Tubes. If neither filament is lighted, it indicates transformer malfunction or a broken wire in the flame safeguard control. Replace the control.
3. If 1 or both filaments are lighted, substitute new tubes one at a time. After each tube replacement, test for pull-in of the flame relay in the flame safeguard control by holding a flame (match or cigarette lighter) in front of viewing window.
4. If necessary, replace 113228 UV sensing tube and check for pull-in of the flame relay in the control as in step 3 above.
5. If tube replacement does not clear up the trouble, replace the C7012.

SERVICE

CAUTION

1. Only qualified service technicians should attempt to service or repair flame safeguard controls and burner systems.
2. Open the master switch to disconnect power before removing or installing the detector or its cover.

PERIODIC MAINTENANCE

Scheduled periodic maintenance is necessary for proper functioning.

1. Replace 113236 and 115330 Electron Tubes annually. These tubes are tested by Honeywell to ensure reliability and safety. **DO NOT REPLACE WITH COMMERCIAL SUBSTITUTES.** Tubes of other manufacturer's will cause nuisance shutdowns.

2. Do not replace the UV sensing tube unless it operates improperly. Order Part No. 113228.

3. Clean the quartz window or lens periodically with a clean cloth on the end of an eraser type pencil. It is not necessary to remove the window or lens from the mount.

To gain access to window or lens on the C7012E, loosen the 3 screws holding case to mounting adapter, rotate case and remove unit. On the C7012F, disconnect the unit at the union; then loosen and remove the 4 bolts holding the mounting plate from the case. The window is now accessible.

NOTE: A quick check on the window can be made by measuring the flame signal as described in the ADJUSTMENTS AND CHECKOUT section. If the current is not steady, clean the window. If still unsteady, investigate further.

4. Adjust burner system for smoothest, most reliable operation as recommended by burner manufacturer.

REMOVAL OF C7012 TUBES

1. De-energize C7012. Remove the detector cover.
2. Remove 115330 and 113236 Electron Tubes by pulling them from their sockets.
3. To remove the UV sensing tube, Part No. 113228, see Fig. 17.
 - a. Bend alignment guide (A) enough to free tip of UV tube (B).
 - b. Insert screwdriver between tube base and socket at point (C). Gently pry tube out of socket.
 - c. Use caution; move UV tube only in the manner just described.
 - d. Use care when replacing the UV tube. Make certain UV tube is placed in the same position as the tube removed.

IMPORTANT

Be very careful not to kink or otherwise damage the flexible shutter (D) or shutter assembly (E).

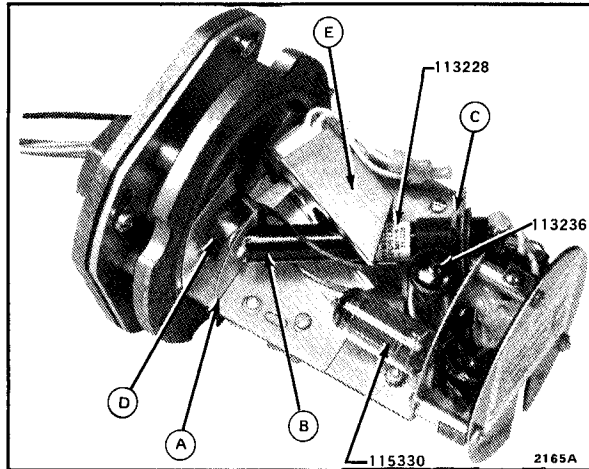

FIG. 17—INTERNAL VIEW OF THE C7012 SHOWING THE LOCATION OF THE TUBES.

REPLACEMENT OF QUARTZ VIEWING WINDOW (OR MAGNIFYING LENS)

IMPORTANT

Quartz window or lens must be used. Ordinary glass filters out ultraviolet radiation.

C7012E

1. Remove both parts of mounting flange and cover.
2. If the quartz window and 3 rubber mounting washers are attached to the mounting flange, proceed with step 5, below.
3. Remove the UV sensing tube (Part No. 113228) as described under Removal of C7012 Tubes.
4. From the inside of the detector, push out the quartz window and the 3 rubber mounting washers. Use a pencil or similar rod.
5. Replace 1 of the rubber washers in the cavity. Place the new quartz window (flat or curved surface down, it doesn't matter) on the washer; then place 2 rubber washers (only 1 for a magnifying lens) on top of the window.
6. Replace the mounting flange first (to seal the window assembly); replace the UV tube (Part No. 113228); then replace the cover.

C7012F

1. Remove pipe flange (near union). Remove the 4 bolts which hold it in place.
2. Unscrew coupling which contains inner lens.
3. Remove threaded insert.
4. Remove O-ring and window.
5. Replace window, O-ring, threaded insert, and coupling.
6. Bolt flange to case with the 4 bolts.