



MICRO SWITCH™
Miniature Sealed Basic Switches
SE and XE Series



MICRO SWITCH™ SE and XE Series Miniature Sealed Basic Switches

Honeywell SE and XE miniature sealed basic switches are designed for precise and reliable position indication of critical applications on aircraft and military systems. The applications range from military and commercial aircraft and helicopters to military land vehicles (track and wheeled vehicles). These switches are also suitable for other commercial and industrial applications where a degree of environmental sealing is required.

The environmentally sealed SE Series is designed for demanding applications where water and/or particulate contaminant is present along with the potential for a wide range of temperatures. The SE Series incorporates the Honeywell time-proven MICRO SWITCH™ SM Series electromechanical switches in the SE housing.

The environmentally sealed miniature XE Series is similar to the SE Series except smaller in package size, utilizing the Honeywell MICRO SWITCH™ SX subminiature electromechanical switch. In addition, select Honeywell XE switches are MIL-PRF-8805 qualified satisfying the requirements where a military qualified or compliant switch is required.

To add to the versatility of the SE and XE family of products, CSA and UL certified products are available where the application is not aerospace or military related.

What makes our switches better?

- SE Series is certified by UL and CSA. XE Series holds approval from UL and within the family qualified to MIL-PRF-8805
- Built with high quality MICRO SWITCH™ switching mechanism: SE Series features MICRO SWITCH™ SM switches and XE Series is built with MICRO SWITCH™ SX switches
- Available with pin plungers or auxiliary levers to meet equipment requirements
- Designed for control of circuits ranging from logic level to power duty



***Big performance
in a little package.***

HIGH PERFORMANCE • DURABILITY
COMPACT • CUSTOMIZATION/CONFIGURABLE

Features and Benefits

MIL-QUALIFIED AND AGENCY CERTIFIED

Military qualified listings offered in the MICRO SWITCH™ XE product family are for onboard or support equipment as specified. UL and CSA certified products are available for use where the application is not aerospace or military related.

COMPACT AND SEALED

Miniature overall package size **requires less space on the equipment.** SE and XE Series switches are environmentally sealed in a small package for stringent indoor or outdoor applications where liquid and/or particulate contaminants are present.

Tiny, tough, and high-temp rated

WELL SUITED FOR HIGH TEMPERATURES

SE/XE switches boast temperature ratings from -53 °C to 105 °C [-65 °F to 221 °F] for design flexibility, with **high temperature options** to 149 °C [300 °F].

LOW VOLTAGE AND POWER DUTY CAPABILITY

SE/XE product are available with **silver contacts** for control of power duty circuits or **gold contacts** for control of logic level circuits.

LEVERS FURTHER EXPAND FUNCTIONALITY

Auxiliary actuators expand the capability of the products for additional applications.

RANGE OF TERMINATION OPTIONS

Electrical connectivity options include solder post, preleaded with MIL-rated leadwire, or custom connectivity to **decrease installation time.**

Potential Applications



MILITARY AIRCRAFT AND HELICOPTERS

- Monitor doors or panels whether open/closed or locked/unlocked
- Mechanical position of actuators
- Valve position open or closed in conjunction with the hydraulics, fuel, and other systems
- Missile, bomb, and ordnance systems

COMMERCIAL AIRCRAFT AND HELICOPTERS

- Monitor doors or panels whether open/closed or locked/unlocked
- Mechanical position of actuators
- Valve position open or closed in conjunction with the hydraulics, fuel, and other systems



AVIATION GROUND SUPPORT EQUIPMENT

- Monitoring doors or panels
- Valve position whether open or closed

MILITARY LAND VEHICLES (TRACK AND WHEELED VEHICLES)

- Monitor position of doors, guards
- Monitor position of valves and solenoids

MICRO SWITCH™ Miniature Sealed Basic Switches

Table 1. Specifications

Characteristic	SE Series	XE Series
Description	environmentally sealed switch	environmentally sealed miniature switch
Housing material	Anodized aluminum	Anodized aluminum
Mechanical endurance	please contact info.sc@honeywell.com for details	25,000
Electrical endurance	please contact info.sc@honeywell.com for details	25,000
Circuitry	SPST (NC), SPST (NO), SPDT	SPST (NC), SPST (NO), SPDT
Electrical termination	epoxy sealed leadwire, (0,52 mm ² [20 awg]) or epoxy sealed solder pins	epoxy sealed leadwire, (0,52 mm ² [20 awg]) or epoxy sealed solder pins
Electrical rating	5 A @ 30 Vdc; 5 A @ 250 Vac, 60 Hz	7 A @ 28 Vdc; 7 A @ 250 Vac, 60 Hz
Sealing	Symbol 3 “watertight” per MIL-PRF-8805	Symbol 3 “watertight” per MIL-PRF-8805
Temperature range	-53 °C to 105 °C [-65 °F to 221 °F] (standard) -26 °C to 85 °C [-15 °F to 185 °F] (5SE Series)	-53 °C to 105 °C [-65°F to 221 °F] (standard) -26 °C to 85 °C [-15 °F to 185 °F] (5XE Series)
Temperature range (optional)	please contact info.sc@honeywell.com for details	-53 °C to 149 °C [-65°F to 300 °F] (14XE Series)
Vibration	Grade 2 (15 G) per MIL-PRF-8805	Grade 2 (15 G) per MIL-PRF-8805
Approvals	UL, CSA	UL, MIL-PRF-8805
Actuators	Top pin plunger, optional auxiliary actuators available	Top pin plunger, optional auxiliary actuators available

Table 2. Electrical Ratings

Rating code	SE/XE Series
A	Sea level @ 28 Vdc; 5 A res. and 3 A ind. 50,000 feet @ 28 Vdc; 5 A res. and 2.5 A ind. General purpose; 5 A res. and 5 A ind. at 125 or 250 Vac, 60 Hz
B	UL and CSA rating; 5 A at 125 or 250 Vac, 60 Hz
C	Sea level @ 28 Vdc; 7 A res. and 4 A ind. 50,000 feet @ 28 Vdc; 7 A res. and 2.5 A ind. General purpose; 7 A res. and 4 A ind. at 115 Vac, 400 Hz
D	UL rating; 7 A at 125 or 250 Vac, 60 Hz
E	Sea level @ 28 Vdc; 7 A res. and 4 A ind. 50,000 feet @ 28 Vdc; 7 A res and 2.5 A ind.
F	Logic level @ 28 Vdc; 1 amp res. and 0.50 A ind.

SE and XE Series

ELECTROMECHANICAL SWITCHES

Definitions below explain the meaning of operating characteristics. Characteristics shown in tables were chosen as most significant. They are taken at normal room temperature and humidity. These may vary as temperature and humidity conditions differ. Sketches show how characteristics are measured for in-line plunger actuation.

Linear dimensions for in-line actuation are from top of plunger to a reference line, usually the center of the mounting holes.

Differential Travel (D.T.) – Plunger or actuator travel from point where contacts “snap-over” to point where they “snap-back.”

Free Position (F.P.) – Position of switch plunger or actuator when no external force is applied (other than gravity).

Full Overtravel Force – Force required to attain full overtravel of actuator.

Operating Position (O.P.) – Position of switch plunger or actuator at which point contacts snap from normal to operated position. Note that in the case of flexible or adjustable actuators, the operating position is measured from the end of the lever or its maximum length. Location of operating position measurement shown on mounting dimension drawings.

Operating Force (O.F.) – Amount of force applied to switch plunger or actuator to cause contact “snap-over.” Note in the case of adjustable actuators, the force is measured from the maximum length position of the lever.

Overtravel (O.T.) – Plunger or actuator travel safely available beyond operating position.

Pretravel (P.T.) – Distance or angle traveled in moving plunger or actuator from free position to operating position.

Release Force (R.F.) – Amount of force still applied to switch plunger or actuator at moment contacts snap from operated position to unoperated position.

Total Travel (T.T.) – Distance from actuator free position to overtravel limit position.

IN-LINE PLUNGER ACTUATION

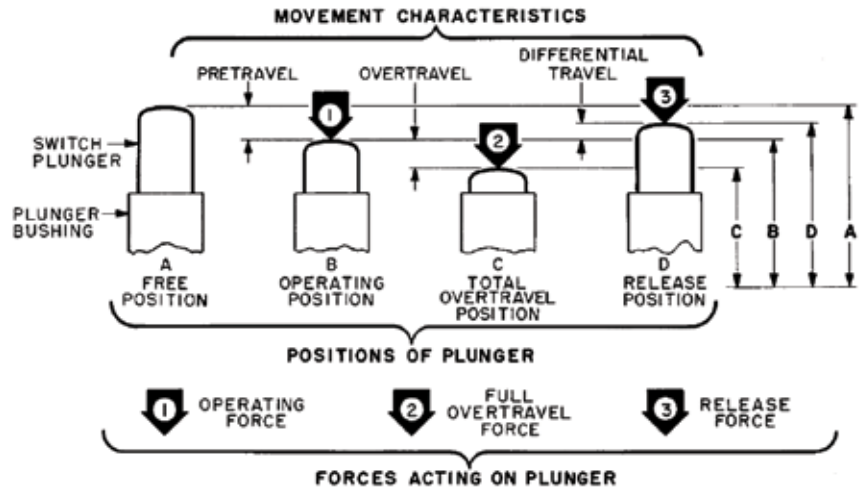



MICRO SWITCH™ Miniature Sealed Basic Switches

O.F. • Operating force
 R.F. • Release force
 P.T. • Pretravel
 O.T. • Overtravel
 D.T. • Differential travel
 O.P. • Operating position

MICRO SWITCH™ SE PRODUCT SPECIFICATIONS AND LISTINGS

Contact your Honeywell rep or distributor for additional listings



	Catalog Listing	Elect. Rating Spec. (page 5)	Contacts	Termination mm [in]	O.F. g [oz]	R.F. min. g [oz]	P.T. max. mm [inches]	O.T. min. mm [inches]	D.T. max. mm [inches]	O.P. nom. mm [inches]	Comment
 (see Figure 1)	1SE1	A	SPDT	Wire leads (3) 305 [12]	142 to 482 [5 to 17]	113 [4]	1,27 [0.050]	0,08 [0.003]	0,1 [0.004]	10,8 [0.425]	General purpose
	1SE2	A	SPST, NC	Wire leads (2) 305 [12]	142 to 482 [5 to 17]	113 [4]	1,27 [0.050]	0,08 [0.003]	0,1 [0.004]	10,8 [0.425]	Single circuit only
	1SE3	A	SPST, NO	Wire leads (2) 305 [12]	142 to 482 [5 to 17]	113 [4]	1,27 [0.050]	0,08 [0.003]	0,1 [0.004]	10,8 [0.425]	Single circuit only
	1SE401	F	SPDT	Wire leads (3) 305 [12]	142 to 482 [5 to 17]	113 [4]	1,27 [0.050]	0,08 [0.003]	0,1 [0.004]	10,8 [0.425]	Gold bifurcated contacts
	4SE1	B	SPDT	Wire leads (3) 305 [12]	142 to 482 [5 to 17]	113 [4]	1,27 [0.050]	0,08 [0.003]	0,1 [0.004]	10,8 [0.425]	UL, CSA
	5SE1	A	SPDT	Wire leads (3) 305 [12]	142 to 482 [5 to 17]	113 [4]	1,27 [0.050]	0,08 [0.003]	0,1 [0.004]	10,8 [0.425]	Oil resistant fluorosilicone seal
	7SE1	A	SPDT	Wire leads (3) 305 [12]	113 to 227 [4 to 8]	57 [2]	1,27 [0.050]	0,08 [0.003]	0,1 [0.004]	10,8 [0.425]	Lower force
 (see Figure 2)	1SE1-T	A	SPDT	Solder pins	142 to 482 [5 to 17]	113 [4]	1,27 [0.050]	0,08 [0.003]	0,1 [0.004]	10,8 [0.425]	Solder terminals
	12SE4-T	A	SPDT	Solder pins	142 to 539 [5 to 19]	113 [4]	1,27 [0.050]	0,08 [0.003]	0,1 [0.004]	10,8 [0.425]	Higher force

SE and XE Series

O.F. • Operating force
 R.F. • Release force
 P.T. • Pretravel
 O.T. • Overtravel
 D.T. • Differential travel
 O.P. • Operating position

MICRO SWITCH™ XE PRODUCT SPECIFICATIONS AND LISTINGS

Contact your Honeywell rep or distributor for additional listings

	Catalog Listing	Elect. Rating Spec. (page 5)	Contacts	Termination mm [in]	O.F. g [oz]	R.F. min. g [oz]	P.T. max. mm [in]	O.T. min. mm [in]	D.T. max. mm [in]	O.P. nom. mm [in]	Comment
 (see Figure 3)	1XE1* [MS27994-1]	C	SPDT	Wire leads (3) 305 [12]	142 to 482 [5 to 17]	113 [4]	1,27 [0.050]	0,1 [0.004]	0,13 [0.005]	10,8 [0.425]	MIL-PRF 8805 applications
	1XE201* [MS27994-4]	C	SPDT	Wire leads (3) 305 [12]	142 to 482 [5 to 17]	113 [4]	1,27 [0.050]	0,1 [0.004]	0,13 [0.005]	10,8 [0.425]	MIL-PRF 8805 applications
	1XE2-3	C	SPNC	Wire leads (2) 914 [36]	142 to 482 [5 to 17]	113 [4]	1,27 [0.050]	0,1 [0.004]	0,13 [0.005]	10,8 [0.425]	Normally closed circuit
	1XE3	C	SPNO	Wire leads (3) 305 [12]	142 to 482 [5 to 17]	113 [4]	1,27 [0.050]	0,1 [0.004]	0,13 [0.005]	10,8 [0.425]	Normally open circuit
	1XE301* [MS27994-5]	F	SPDT	Wire leads (3) 305 [12]	142 to 482 [5 to 17]	113 [4]	1,27 [0.050]	0,1 [0.004]	0,13 [0.005]	10,8 [0.425]	Gold bifurcated contacts
	4XE1	D	SPDT	Wire leads (3) 305 [12]	142 to 482 [5 to 17]	113 [4]	1,27 [0.050]	0,1 [0.004]	0,13 [0.005]	10,8 [0.425]	UL
	5XE1	C	SPDT	Wire leads (3) 305 [12]	142 to 482 [5 to 17]	113 [4]	1,27 [0.050]	0,1 [0.004]	0,13 [0.005]	10,8 [0.425]	Oil resistant fluorosilicone seal
	14XE1	E	SPDT	Wire leads (3) 305 [12]	255 [9] max.	57 [2]	0,76 [0.030]	0,1 [0.004]	0,13 [0.005]	10,9 [0.430]	High temp. 149 °C [300 °F]
 (see Figure 4)	1XE401-T	F	SPDT	Solder pins	142 to 482 [5 to 17]	85 [3]	1,27 [0.050]	0,1 [0.004]	0,13 [0.005]	10,8 [0.425]	Gold bifurcated contacts
	14XE1-T	E	SPDT	Solder pins	255 [9] max.	57 [2]	0,76 [0.030]	0,1 [0.004]	0,13 [0.005]	10,9 [0.430]	High temp. 149 °C [300 °F]
	14XE1-T* [MS27994-3]	C	SPDT	Solder pins	142 to 482 [5 to 17]	113 [4]	1,27 [0.050]	0,1 [0.004]	0,13 [0.005]	10,8 [0.425]	Mil-PRF 8805

* Reference MIL-PRF-8805/32

MICRO SWITCH™ Miniature Sealed Basic Switches

MICRO SWITCH™ JE SERIES AUXILIARY ACTUATORS FOR THE MICRO SWITCH™ SE SERIES SWITCHES (specifications when assembled to 1SE1)

		Description	Actuator Length	Operating Force max.	Release Force min.	Pretravel max.	Overtravel min.	Differential Travel max.	Operating Point nom.	Free Position nom.
JE-1	 (see Figure 5)	Straight leaf (mounting hardware included)	16,8 mm [0.66 in]	340 g [12 oz]	57 g [2 oz]	3,81 mm [0.150 in]	0,38 mm [0.015 in]	0,64 mm [0.025 in]	11,2 mm [0.44 in]	15 mm [0.59 in]
JE-4	 (see Figure 6)	Roller leaf, roller rotated 90° to switch axis (mounting hardware included)	16,8 mm [0.66 in]	340 g [12 oz]	57 g [2 oz]	3,81 mm [0.150 in]	0,38 mm [0.015 in]	0,64 mm [0.025 in]	16,3 mm [0.64 in]	20,1 mm [0.79 in]
JE-5	 (see Figure 7)	Roller leaf (mounting hardware included)	15,2 mm [0.60 in]	340 g [12 oz]	57 g [2 oz]	3,81 mm [0.150 in]	0,38 mm [0.015 in]	0,64 mm [0.025 in]	16,3 mm [0.64 in]	20,1 mm [0.79 in]
JE-17	 (see Figure 8)	Roller leaf [reversed] (mounting hardware included)	15,2 mm [0.60 in]	340 g [12 oz]	57 g [2 oz]	3,81 mm [0.150 in]	0,38 mm [0.015 in]	0,64 mm [0.025 in]	16,3 mm [0.64 in]	20,1 mm [0.79 in]
JE-21	 (see Figure 9)	Roller lever	13,7 mm [0.540 in]	170 g [6 oz]	28 g [1 oz]	2,54 mm [0.100 in]	0,25 mm [0.01 in]	0,41 mm [0.016 in]	16,3 mm [0.64 in]	18,8 mm [0.74 in]
JE-22	 (see Figure 10)	Tandem roller lever	17,8 mm [0.700 in]	482 g [17 oz]	113 g [4 oz]	2,54 mm [0.100 in]	0,15 mm [0.006 in]	0,3 mm [0.012 in]	16,8 mm [0.66 in]	19,3 mm [0.76 in]

** Travel characteristics on tandem actuators vary with actual basic switch characteristics

MICRO SWITCH™ JM SERIES AUXILIARY ACTUATORS FOR THE MICRO SWITCH™ XE SERIES SWITCHES (specifications when assembled to 1XE1)

		Description	Actuator Length	Operating Force max.	Release Force min.	Pretravel max.	Overtravel min.	Differential Travel max.	Operating Point nom.	Free Position nom.
JM-1	 (see Figure 11)	Straight leaf (mounting hardware included)	11,4 mm [0.45 in]	595 g [21 oz]	85 g [3 oz]	3,18 mm [0.125 in]	0,23 mm [0.009 in]	0,3 mm [0.012 in]	10,8 mm [0.425 in]	14 mm [0.55 in]
JM-5	 (see Figure 12)	Roller leaf (mounting hardware included)	9,5 mm [0.375 in]	595 g [21 oz]	85 g [3 oz]	3,18 mm [0.125 in]	0,23 mm [0.009 in]	0,3 mm [0.012 in]	15,9 mm [0.625 in]	19,1 mm [0.75 in]

** Travel characteristics on tandem actuators vary with actual basic switch characteristics

SE and XE Series

PRODUCT AND ACTUATOR DIMENSIONS

Figure 1. MICRO SWITCH™ SE Dimensions, Wire Lead

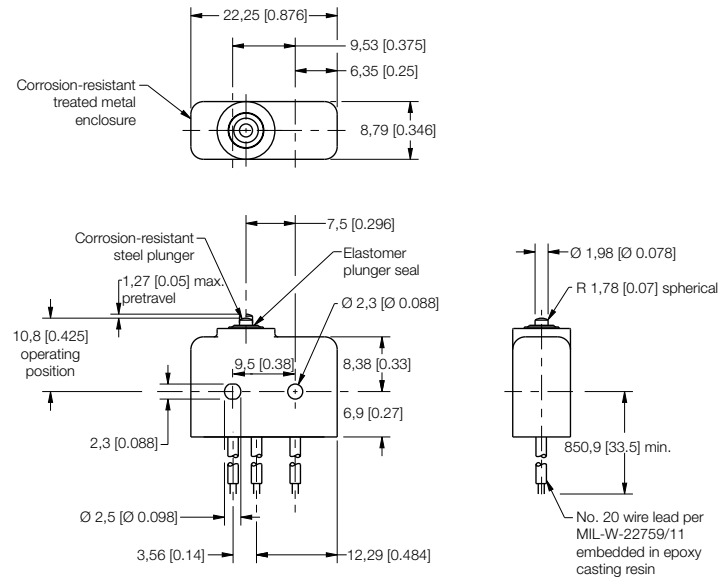

Figure 2. MICRO SWITCH™ SE Dimensions, Solder Terminal

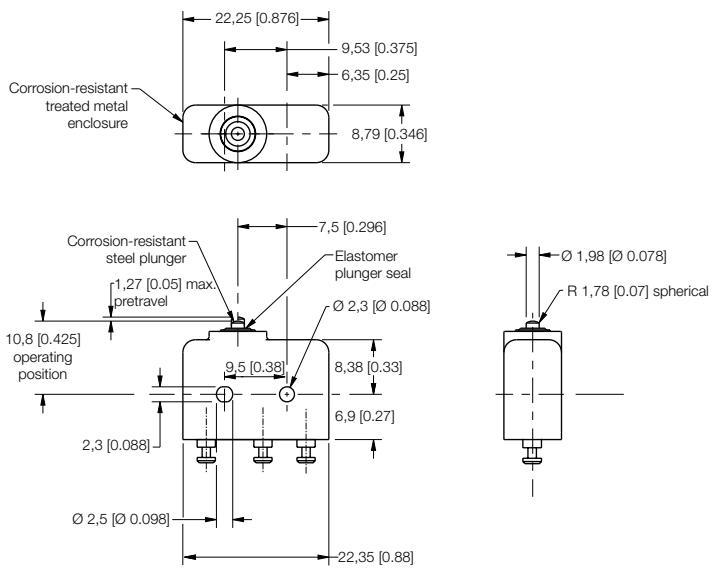

Figure 3. MICRO SWITCH™ XE Dimensions, Wire Lead

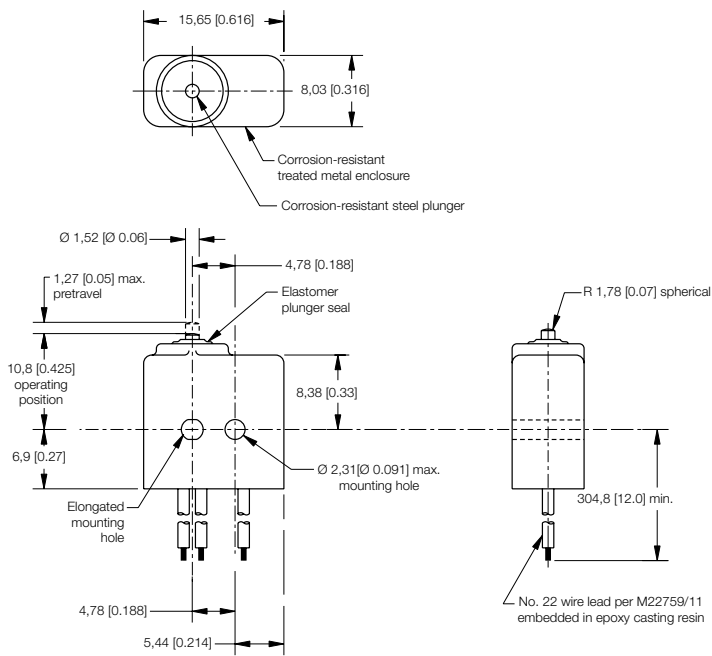
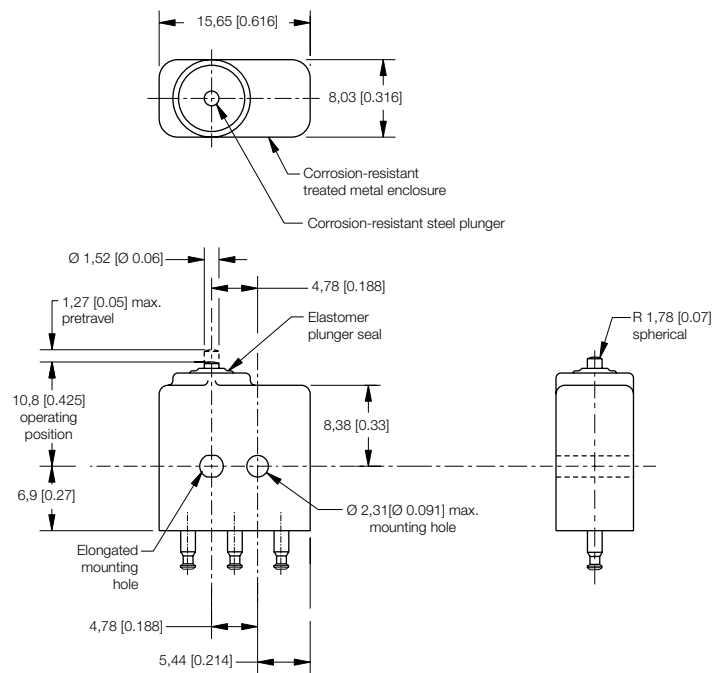

Figure 4. MICRO SWITCH™ XE Dimensions, Solder Terminal



MICRO SWITCH™ Miniature Sealed Basic Switches

Figure 5. JE-1 Dimensions

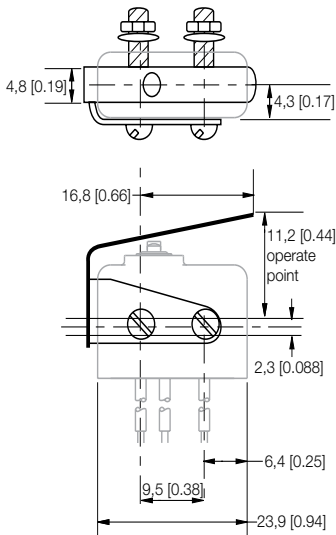

Figure 6. JE-4 Dimensions

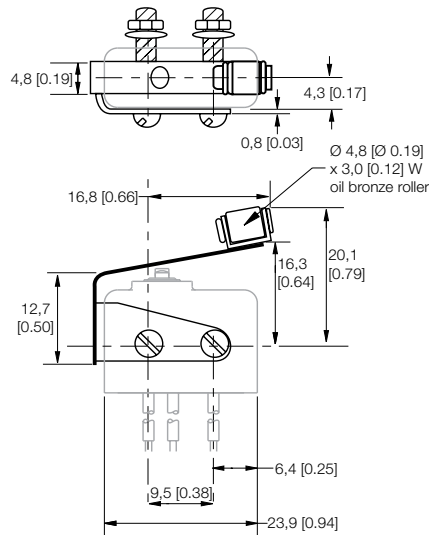

Figure 7. JE-5 Dimensions

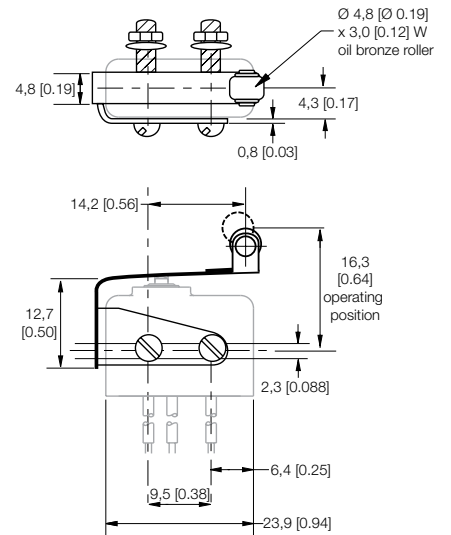

Figure 8. JE-17 Dimensions

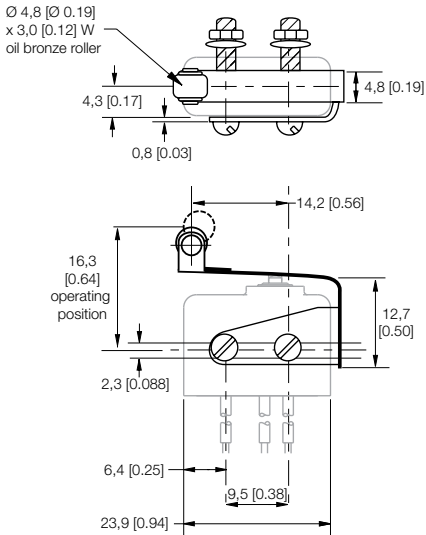

Figure 9. JE-21 Dimensions

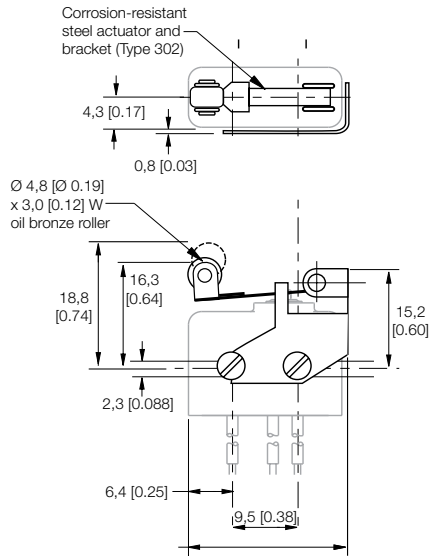

Figure 10. JE-22 Dimensions

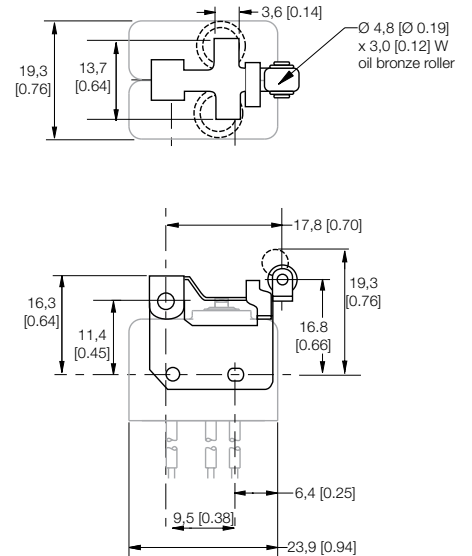

Figure 11. JM-1 Dimensions

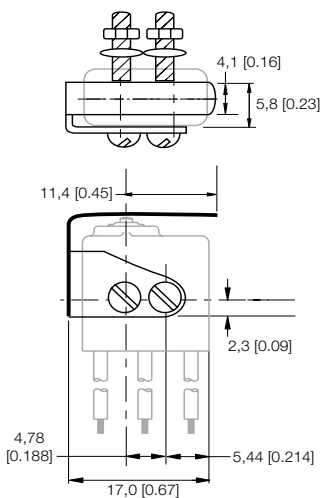

Figure 12. JM-5 Dimensions

