

VV, VP, VB & MS SERIES FOR VQ400M CLASS "A" VALVES

PRODUCT HANDBOOK



Figure 1: Vent Valve "right"



Figure 2: Vent Valve "left"



Figure 3: Pilot Valve

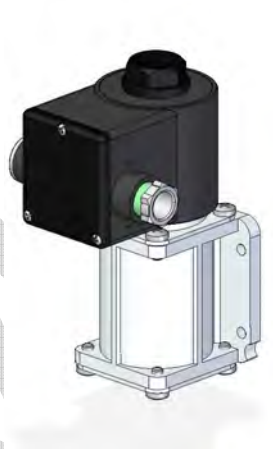

Figure 4: By Pass Valve



Figure 5: CPI switch

APPLICATION

The **VV Series** class "A" vent valves are intended to be used in combination with the VQ400M series combination valve. The valves are supplied as a kit which enables the field mounting of the vent valve onto the VQ400M possible.

The **VP Series** class "A" pilot valves are intended to be used in combination with the VQ400M series combination valve. The valves are supplied as a kit which enables the field mounting of the pilot valve onto the VQ400M possible.

The valves are available in two different basic versions:

- 1: DN20 (3/4") Fast Opening
- 2: DN 20 (3/4") Slow Open version

The **VB Series** class "A" by pass valves are intended to be used in combination with the VQ400M series combination valve. The valves are supplied as a kit which enables the field mounting of the by pass valve onto the VQ400M possible.

The valves are available in two different basic versions:

- 1: DN20 (3/4") Fast Opening
- 2: DN 20 (3/4") Slow Open version

The **MS Series** CPI switches are intended to be used in combination with the VQ400M series combination valve. The switches are supplied as a kit which enables the field mounting of the CPI switch onto the VQ400M possible

SPECIFICATIONS

The **Vent Valves** are supplied with kit KTVQM002 containing:

- Valve Q.ty: 1
- Mounting screws M5 x 14 Q.ty: 4
- Mounting gasket Q.ty: 1

The **Pilot Valves** are supplied with kit KTVQM002 containing:

- Valve Q.ty: 1
- Mounting screws M5 x 14 Q.ty: 4
- Mounting gasket Q.ty: 1

The **Pilot Valves** are supplied with kit KTVQM001 containing:

- Valve Q.ty: 1
- Mounting screws M5 x 14 Q.ty: 4
- Mounting gasket Q.ty: 1

The **CPI switches** are supplied in "ready to fit and use" state

Models

See for model overview: survey 50040301.
Available through Honeywell sales representative.

Dimension

VV420: See drawing: INST0176

VP420: See drawing: INST0175

VB420: See drawing: INST0174

MS06: See drawing: INST0181

Available through Honeywell sales representative

Ambient temperature range

-15 ... 60 degrees C.

Maximum operating pressure

: 360 mbar

Opening time:

- VV series: N.A.
- VB & VP series fast open: < 1 sec
- VB & VP series slow open: Adjust.: 1 ...30 sec

Closing time:

- Vent valve: <1 sec after energization
- VP & VB series: <1 sec

Electrical connections

- Plug connection according to PG11
- Three pin plug connector according to DIN EN 175301-803 or ISO 4400, see page 10

Supply Voltages VV, VB & VP:

- Line voltage: 230V 50/60 Hz
- 115V 50/60 Hz
- 120V 50/60 Hz

Coils for rectified AC with rectifier in connection box

Maximum operating parameters MS:

- Voltage: 250 V
- Current: 3 A

Operational Voltage range

Valves will function between 85% and 110% of the rated voltage.

Enclosure VV, VB & VP:

- IP54 in combination with PG11 connection
- IP65 in combination with DIN-plug connection

Enclosure MS:

IP65

Coil Insulation solenoid valves

Insulation material specified according Class F

Body material

- VV, VB & VP: Aluminum alloy die cast body
- MS: Nylon

Maximum working frequency

VV420:

VP & VB420 Fast Open: 30 cycles/min

VP & VB420 Slow Open: 1 cycle/min

MS: 30 cycles/min

Closing spring

AISI 302 steel

SPECIFICATIONS cont.

Seals and gaskets

Hydro carbon resistant NBR rubber

Hydro carbon resistant Cork-Nitril rubber

Viton rubber

Duty cycle

Valves suitable for permanent energizing

Designed life time

500000 cycles

Power consumption

Gas valve	Coil nr	Voltage [V]	Power [W]	Current [mA]
VV420	BB020046	115	16,3	156
	BB020046	120	17,8	160
	BB020041	230	18,8	92
VP420	BB020046	115	16,3	156
	BB020046	120	17,8	160
	BB020100	230	14,8	72
VB420	BB020046	115	16,3	156
	BB020046	120	17,8	160
	BB020100	230	14,8	72

Table 1: Power consumption

Capacity: (m³/h air at dP=2.5mbar)

VV420 on VQ400 series: Not applicable

VP420 on VQ420/425: 5.1 See figure 6

VP420 on VQ440/450: 6.8 See figure 7

VB420 on VQ420/425: 4.2 See figure 6

VB420 on VQ440/450 6.1 See figure 7

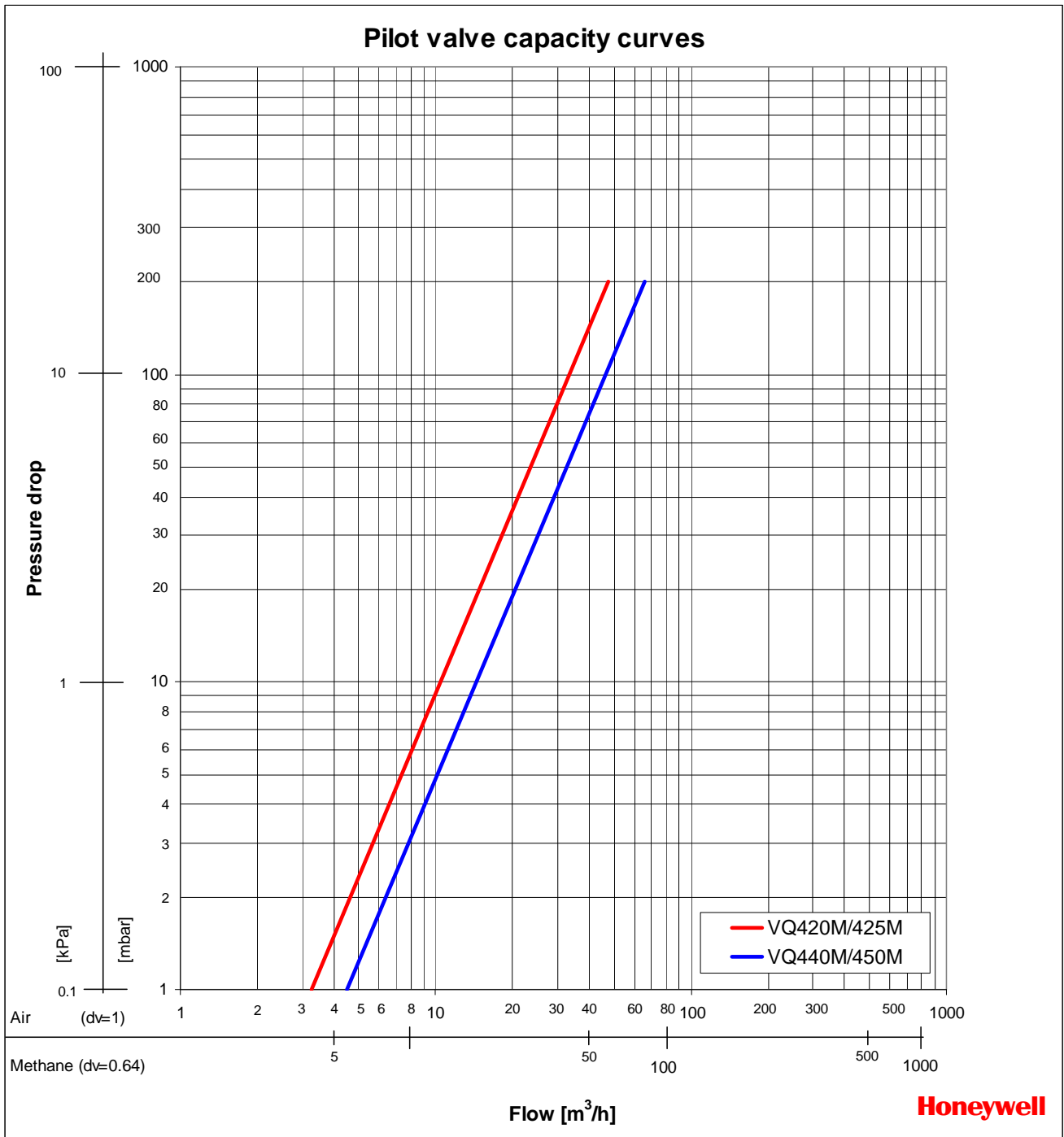

Figure 6: Capacity curve for Pilot valve mounted on main valve

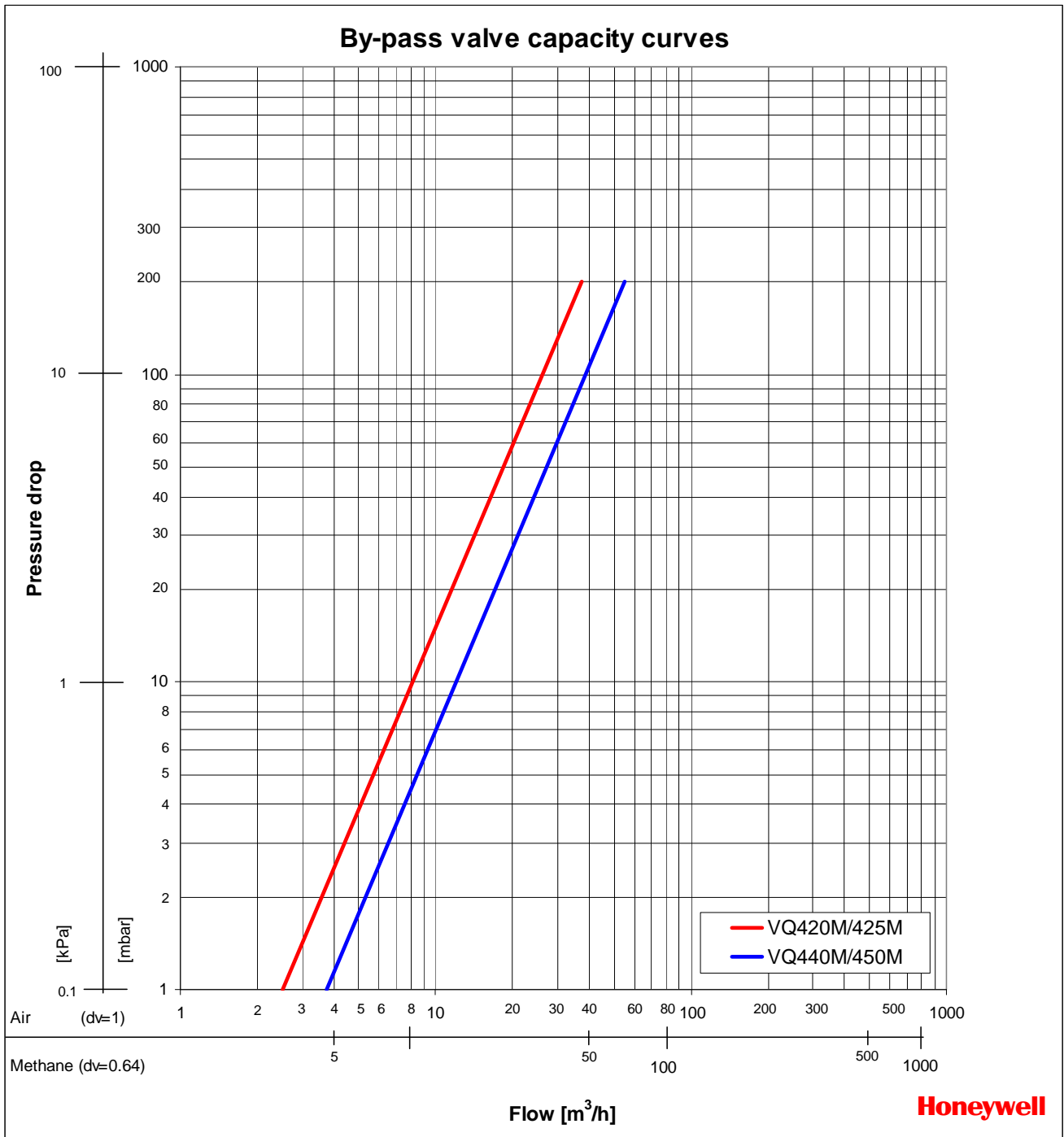

Figure 7: Capacity curve for Bypass valve mounted on main valve

MOUNTING INSTRUCTIONS

VV420 on to VQ420/425M

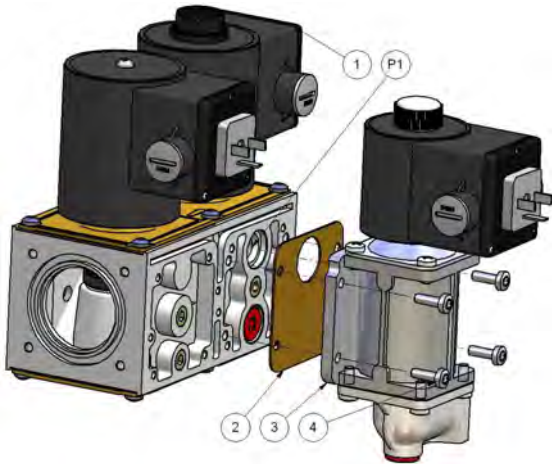

Figure 8: VQ420/425M (vent valve mounted on right side)

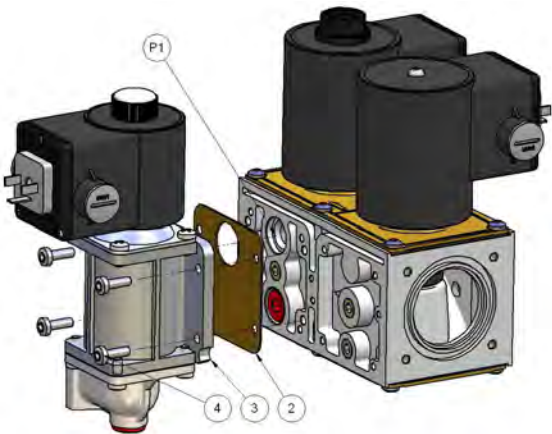

Figure 9: VQ420/425M (vent valve mounted on left side)

VV420 on to VQ440/450M

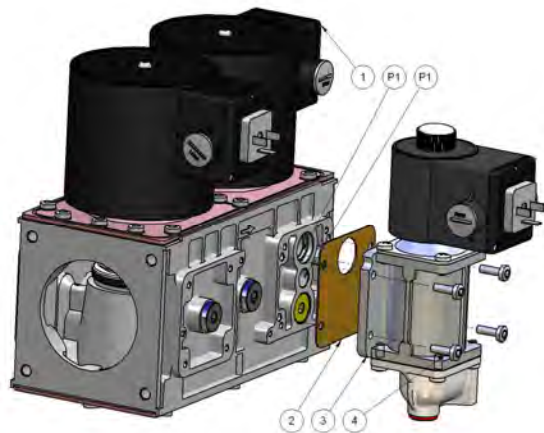

Figure 10: VQ440/450M

Guideline for how to mount VV420 Vent valve:

See figure 8 9 & 10

1: Choose side of VQ400 where to mount valve

2: By looking in direction of gas flow a choice concerning left or right handed models can be made.

3: Remove plug P1

4: Put gasket 2 in place. Mounting holes in gasket match hole pattern on valve body.

5: Put valve in place.

6: Mount screws and fix VV420 to VQ400M by tightening screws clockwise with 5 Nm.

Tool bit to be used: TX25

7: Leak test to be carried out to ensure leak tight connection.

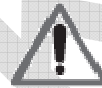

WARNING

- Its not allowed to remove and re-direct orientation of outlet flange of VV420 .

MOUNTING INSTRU. CONT.

VP420 on to VQ420/425M

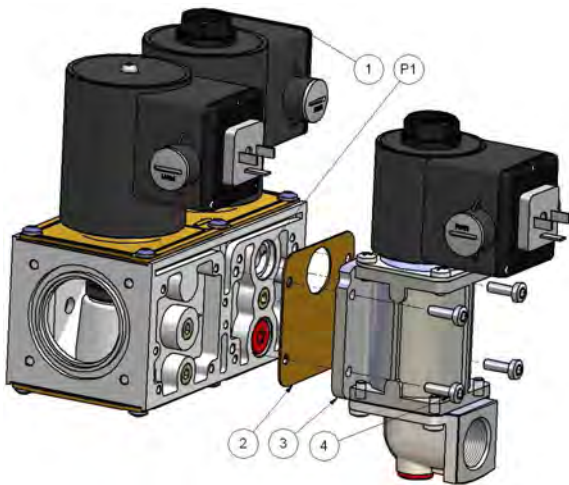

Figure 11: VQ420/425M

VP420 on to VQ440/450M

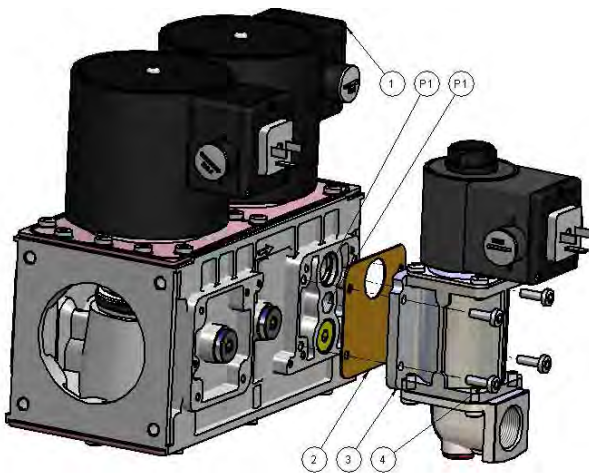

Figure 12: VQ440/450M

Guideline for how to mount VP420 Vent valve:

See figure 11 & 12

1: Choose side of VQ400 where to mount valve

2: Remove plug P1

3: Put gasket 2 in place. Mounting holes in gasket match hole pattern on valve body.

4: Put valve in place.

5: Mount screws and fix VP420 to VQ400M by tightening screws clockwise with 5 Nm.

Tool bit to be used: TX25

6: If required, orientation of angled flange at bottom can be changed to required position. Fastening torque for flange screws after changing orientation flange: 5 Nm.

Tool bit to be used: Cross hatched screw driver.

7: Leak test to be carried out to ensure leak tight connections.

MOUNTING INSTRUC. CONT.

VB420 on to VQ420/425M

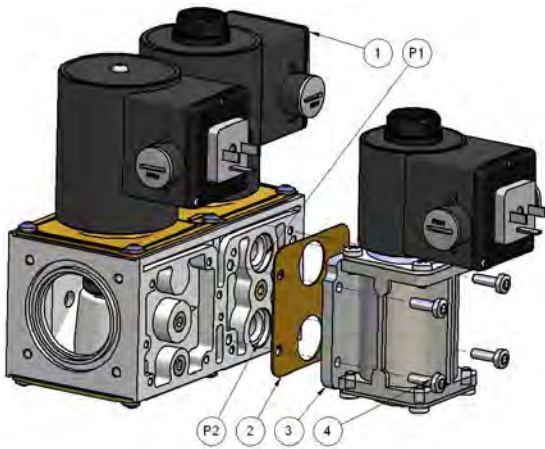

Figure 13: VQ420/425M

Guideline for how to mount VB420 Vent valve:

See figure 13 & 14

1: Choose side of VQ400 where to mount valve

2: Remove plug P1 and P2

3: Put gasket 2 in place. Mounting holes in gasket match hole pattern on valve body.

4: Put valve in place.

5: Mount screws and fix VB420 to VQ400M by tightening screws clockwise with 5 Nm.

Tool bit to be used: TX25

6: Leak test to be carried out to ensure leak tight connections.

VB420 on to VQ440/450M

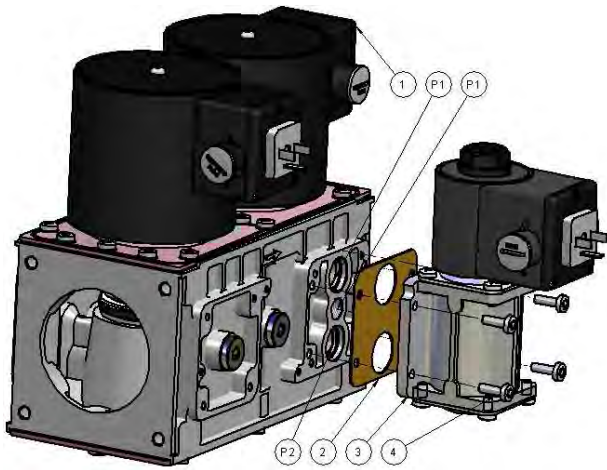

Figure 14: VQ440/450M

Guideline for how to mount MS06 CPI switch:

MS062001/2501 on to VQ420/425M

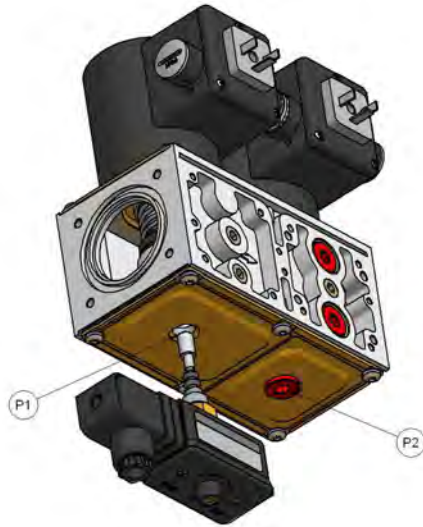

Figure 15: VQ420/425M (CPI mounted to detect V1 position)

MS064001/5001 on to VQ420/425M

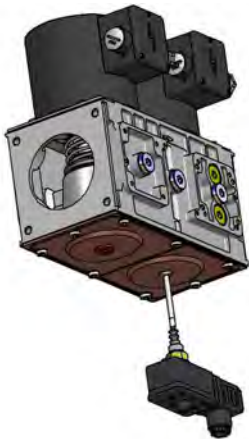

Figure 16: VQ440/450M(CPI mounted to detect V2 position)



Figure 17: VQ440/450M - detail

See figure 15,16 & 17

1: Choose valve to be detected

2: Remove plug P1 for first valve or P2 for second valve

3: Screw CPI switch to VQ400M clockwise tighten by 2,5 Nm. Be sure that terminals 1 and 2 in closed position.

Tool to be used wrench 17

4: If sensing head tight can be turned CPI box to final position.

5: Leak test to be carried out to ensure leak tight connections.

INSTALLATION

IMPORTANT

1. Read these instructions carefully. Failure to follow the instructions could damage the product or cause a hazardous condition.
 2. Check the ratings given in the instructions and on the product to make sure the product is suitable for your application.
 3. The installation has to be carried out by qualified personnel only.
 4. Carry out a thorough checkout when installation is completed.
- Disconnect power supply to the valve actuator before beginning the installation to prevent electrical shock and damage to the equipment.
 - Do not remove the seals and plugs from valves until ready for mounting.
 - Take care that dirt does not enter the gas valves during assembly/handling
 - Complete the electrical connections as instructed in the electrical connection section.

Maintenance and service

The designed lifetime* of this product is 10 years, based on date code, according to:

- a) the standard EN 126
- b) the table on designed lifetime as stated on the Afecor website <http://www.afecor.org/>

We cannot assume that the product can be safely used beyond the mentioned designed lifetime. This lifetime is based on use of the control according manufacturer's instructions.

Regular inspection of the control by authorized personnel in accordance with guidelines of the appliance manufacturer is required.

After reaching the designed lifetime the product has to be replaced by authorized personnel.

*Note: * Warranty as opposed to designed lifetime is described in the delivery terms.*

Mounting position

The gas valves and CPI switches can only be mounted as shown in figures 8 to 17.



WARNING

Tightness test after installation

- Spray all pipe connections and gaskets with a good quality gas leak detection spray.
- Start the appliance and check for bubbles. If a leak is found in a pipe connection, remake the joint. A gasket leak can usually be stopped by tightening the mounting screws, otherwise, replace the gas valve.

Electrical connection



WARNING

- Switch off power supply before making electrical connections.
- All wiring must comply with local codes, ordinances and regulations.

Use lead wire which can withstand 105 °C ambient. The electric ON/OFF operator is provided with a terminal block for electrical connections.

Wiring PG11- VV, VB & VP

Remove screws (A)

Take off protective cover lids and gaskets (B)

Take off plug Pg11 from hole which used for connection.

~~Un-tighten cable support screw (C).~~

Prepare cable

- Remove plastic outside insulation for about 50 – 75 mm.
- Strip wires from plastic insulation for about 5 – 7 mm.

Place cable in cable support screw **(C)**, **steel ring (D)**, **rubber ring (E)** and guide wires through the hole in the cover to the connection block **(DF)**.

Connect wires between plates by tightening the particular screws **(D1F1, D2F2, D3F3)**.

- Left: Phase
- Middle: Earth connection
- Right: Neutral

Tighten cable support screw (C).

Place gasket and cover lid in position (B)

Place screws (A) and tighten screws.

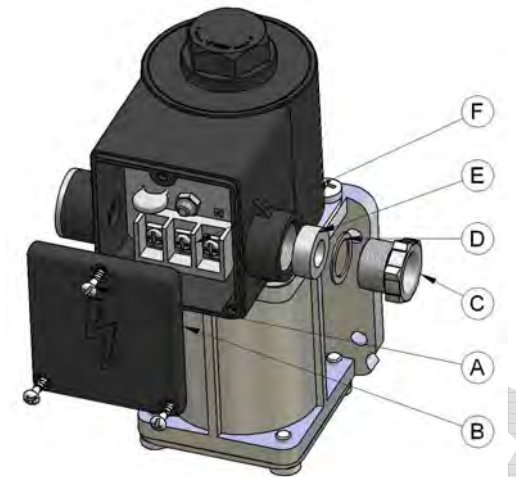
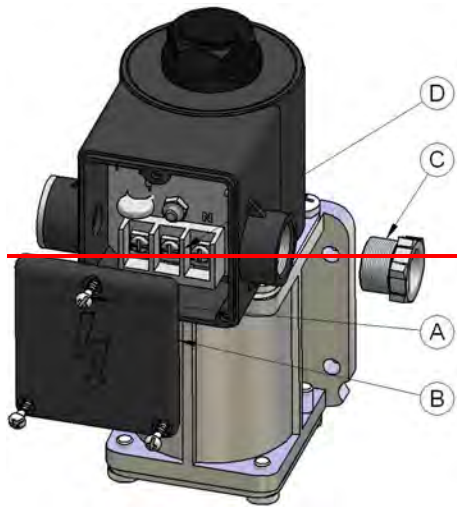

Figure 18: Connection through PG11 bushing

Wiring DIN plug

Follow the instructions supplied by the appliance manufacturer as shown in the figures below.

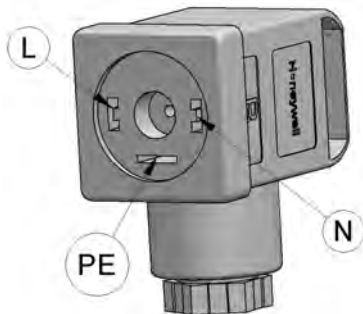

Figure 19: Three pin electrical plug connector (according to ISO 4400 / DIN EN 175301-803).

Wiring DIN plug - MS

Follow the instructions supplied by the appliance manufacturer as shown in the figures below.

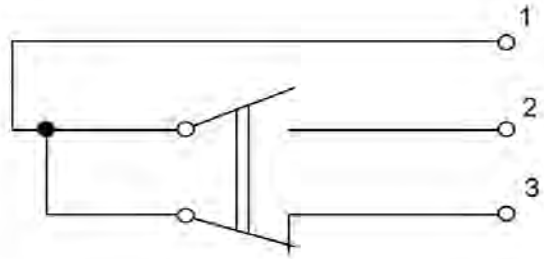

Figure 20: CPI – inside wiring (closed valve position)

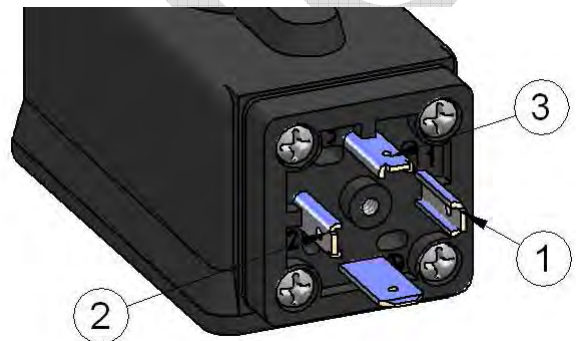

Figure 21: Connection base for four pins plug connector (according to ISO 4400 / DIN EN 175301-803)

ADJUSTMENTS AND FINAL CHECKOUT

The procedures described in this chapter are related to the adjustments on the main gas valve, pilot valve and by-pass valve. For adjustments on the other additional functionalities (e.g. pressure switch), refer to the included instruction sheet of the product in question in the package.



- Adjustments must be made by qualified personnel only.
- To ensure a safe closing of the valves, it is essential that voltage over the terminals of operators is reduced to 0 Volts.

VP & VB valves fast opening

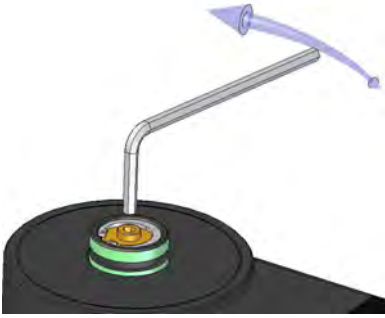

Figure 22: Adjusting flow rate.

Flow rate adjustment (see Fig. 22.)

1. Remove the cap screw from top of the coil.
2. Place a socket head wrench into the adjustment nut.
3. Turn wrench counter-clockwise to increase or clockwise to decrease flow rate.
4. Replace cap screw.

VP & VB valves slow opening

The following characteristics can be adjusted:

- flow rate
- step pressure
- opening speed

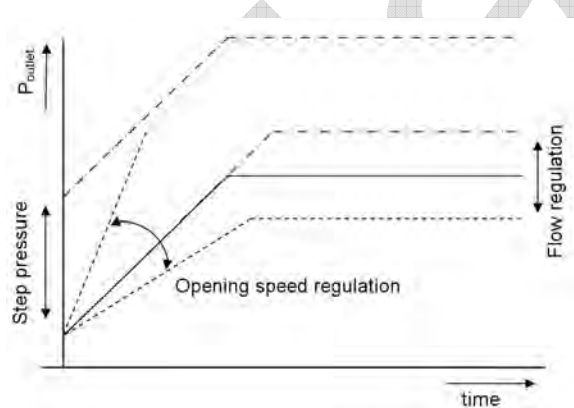

Figure 23: Characterized opening.

IMPORTANT

To ensure a satisfactory setting of the valve the pressure drop over the valve should be at least 10% of the supply pressure or 2.5 mbar which ever is the greatest.

Flow rate adjustment

1. Remove the cap from top of the coil by loosening both screws.
2. Place a wrench on the adjustment hexagon nut.
3. Turn wrench counter-clockwise to increase or clockwise to decrease the flow rate.
4. Replace cap on top of the coil.



Figure 24: Adjusting flow rate.

Step pressure adjustment (see fig. 25.)

1. Remove the cap from top of the coil by loosening both screws.
2. Place a screw driver in the slot of adjustment screw which is situated in center of the valve.
3. Turn screw driver counter-clockwise to increase or clockwise to decrease step pressure.
4. Replace cap on top of the coil.

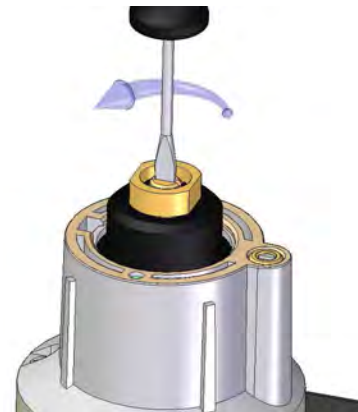

Figure 25: Adjusting step pressure.

Opening speed adjustment

1. Remove the cap from top of the coil by loosening both screws.
2. Place screw driver in the slot of adjustment screw which is of center line.
3. Turn screw driver counter-clockwise to increase the opening speed and therefore the time till full opening will decrease.

4. Turn screw driver clockwise to decrease the opening speed and therefore the time till full opening will increase.
5. Replace cap on top of the coil.

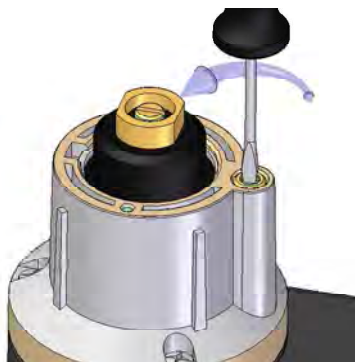

Figure 26: Adjusting opening speed.

CPI switch adjustment

1. Ensure that valve is in closed position (no coil energized)
2. Place a socket head wrench into the adjustment nut.
3. Turn adjustment screw clockwise till terminals 1 and 3 in closed position.
4. Turn the adjustment screw an additional half turn clockwise to achieve some over travel at the switch.
5. Operate valve several times to ensure proper functioning of the switch



Figure 24: CPI switch adjustment

Final checkout of the installation

Set the appliance in operation after any adjustment and observe several complete cycles to ensure that all burner components function correctly.

APPROVALS

The gas valve series **VV**, **VP** & **VB** and CPI switch series **MS**, to be used with VQ series of gas valves, have been designed to meet the European standards:

- EN 161 Automatic shut-off valves
- EN 126 Multifunctional controls

DECLARATION OF CONFORMITY

Honeywell Technologies Sàrl.
Rolle,
Switzerland,

declares under it's sole responsibility that in combination with the VQ Modular Valve product family, the following valves:

pilot valves **VP**, bypass valves **VB**,
and vent valves **VV**

to which this statement relates, are:

- in conformity with the essential requirements of the **Gas Appliance Directive 90/396/EEC** based on EN 126:2004

- in conformity with the essential requirements of the **Low Voltage Directive 2006/95/EC** based on EN 60730-1:2000

- in conformity with the essential requirements of the **EMC Directive 2004/108/EC**

for immunity based on the standard: **EN55014-2:1997** (Immunity, Product Family Standard)

for emission based on the standard: **EN55014-1:2006** (Emission, Product family standard)

Markup

CONSTRUCTION AND WORKING PRINCIPLES

The VP and VB420 series gas valves are class "A" fail safe shut-off valves. The valve is opened by energizing the direct ON / OFF operator. The direct ON / OFF operator consists of a coil and stop sleeve assembly. Inside the top sleeve assembly a plunger is placed which is able to move up and down and thus opening or closing the valve. The plunger is gliding on two anti-friction bearings. Flow regulation is done by adjustable plunger stroke. Valve closing springs are made out of steel AISI 302. Seals and gaskets are manufactured out of hydrocarbon resistant NBR according to DIN 3535 and EN291 or made out of Viton

The VV420 series gas valves are class "A" fail safe vent valves. The valve is closed by energizing the direct ON / OFF operator. The direct ON / OFF operator consists of a coil and stop sleeve assembly. Inside the top sleeve assembly a plunger is placed which is able to move up and down and thus opening or closing the valve. The plunger is gliding on two anti-friction bearings. Valve closing springs are made out of steel AISI 302. Seals and gaskets are manufactured out of hydrocarbon resistant NBR according to DIN 3535 and EN291 or made out of Viton

The MS06 series CPI switches contain micro switches indicating the position of the valve. Closed position is detected by mechanical contact between valve and extension of the switch. If valve opens, the shaft is moved by spring and switch can change over.

ORDERING INFORMATION

Basic OS number structure for valves: VY420X1xxx

VY= VV: Vent Valve
VP: Pilot valve
VB: Bypass valve

420: DN20

X: A: fast closing. Only for Vent valve series
B: Fast Opening with throttle
C: Slow open

Basic OS number structure for CPI switches: MS06xx001

xx: 20: CPI switch suitable for VQ420M series
25: CPI switch suitable for VQ425M series
40: CPI switch suitable for VQ440M series
50: CPI switch suitable for VQ450M series

Honeywell